



FabLink[®]-XP25.4.PR%22

Meat and Poultry Applications

General Conveyance and Breeding Lines

Fruit and Vegetable Application

Elevators, Steam Peeler, Inspection Tables, Blanching Lines

Seafood Applications

Elevators, Inspection Tables, Grading Lines, Trim Lines, Glazing Lines, Cooking Lines

Bakery Applications

Row Dough Handling, Cooling Lines, Icing Lines, Packing Lines, Metal Detectors

FabLink®-XP25.4.PR%22



Pitch	25,4 mm / 1 inch
Belt surface	Open, Smooth surface
Minimum width	50 mm / 1,97 inch
Open Area (%)	22% (Biggest opening 9,44 x 3 mm)
Cleat	Yes (T25, T50, T75, T100)
Sidewall	Yes (h = 25 mm, h = 50 mm, h = 75 mm, h = 100mm)
Pin	Ø 4,5 mm / 0,177 inch
Approved	FDA and EU
Curve	No
Color	Additional colors available
Cleanability	Good
Belt thickness	8,8 mm / 0,346 inch

Product Features and Functional Benefits

Unique sprocket engagement – precise indexing, easy cleaning
 Different openings to optimize performance in cooling and draining applications.
 Extra power, bi-directional belt for long conveyors.
 Unique sprocket engagement reduces pulsation and increases load capacity.
 Chamfered belt edges.

Available Moulded Module Sizes

152,4 mm / 6 inch module
 76,2 mm / 3 inch module

Technical Information

BELT MATERIAL	TENSILE STRENGTH				TEMPERATURE		BELT WEIGHT Kg/m ² / lb/ft ²
	Straight		Curve		°C / ° F (min.)	°C / ° F (max.)	
	N/mm	lb/ft	N/mm	lb/ft			
PP (Polypropylene)	18400	1261	-	-	+5 / +41	+90 / +194	5,5 / 1,13
PE (Polyethylene)	9100	624	-	-	-73 / -99	+66 / +151	5,8 / 1,19
POM (Polyacetal)	32100	2200	-	-	-43 / -45	+110 / +230	7,9 / 1,62

Standard Belt Widths

WIDTH (W)				BELT WIDTH TOLERANCE (max.)
PP-PE		POM		
mm	inch	mm	inch	
152,4	6,0	152,4	6,0	± 0,5 mm
228,6	9,0	228,6	9,0	± 2 mm
304,8	12,0	304,8	12,0	± 2 mm
381,1	15,0	381,1	15,0	± 3 mm
457,2	18,0	457,2	18,0	± 3 mm
533,4	21,0	533,4	21,0	± 3 mm
609,6	24,0	609,6	24,0	± 3 mm
685,8	27,0	685,8	27,0	± 4 mm
762,0	30,0	762,0	30,0	± 4 mm
838,2	33,0	838,2	33,0	± 4 mm
914,4	36,0	914,4	36,0	± 4 mm
990,6	39,0	990,6	39,0	± 4 mm
1066,8	42,0	1066,8	42,0	± 4 mm
1143,0	45,0	1143,0	45,0	± 4 mm

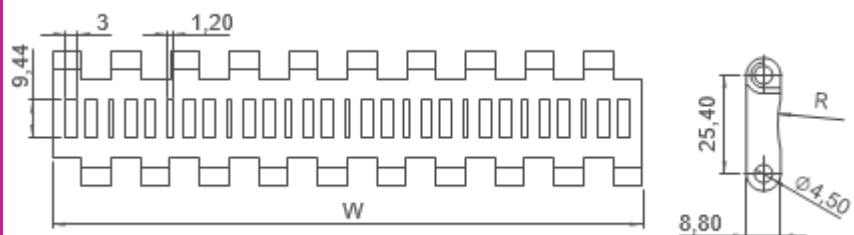

- Standard belt increments 76,2mm
- Non-standard belt increments 15,2mm
- Please contact with customer service for precise belt measurements

Sprockets and Technical Specifications

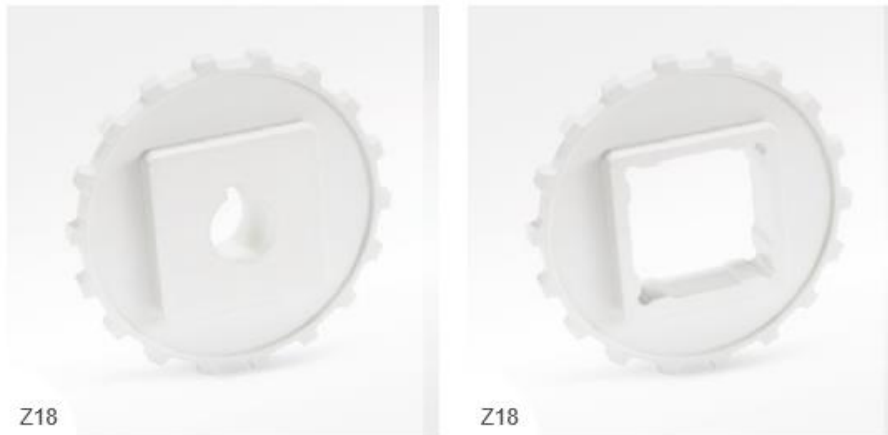

Z18

Z18

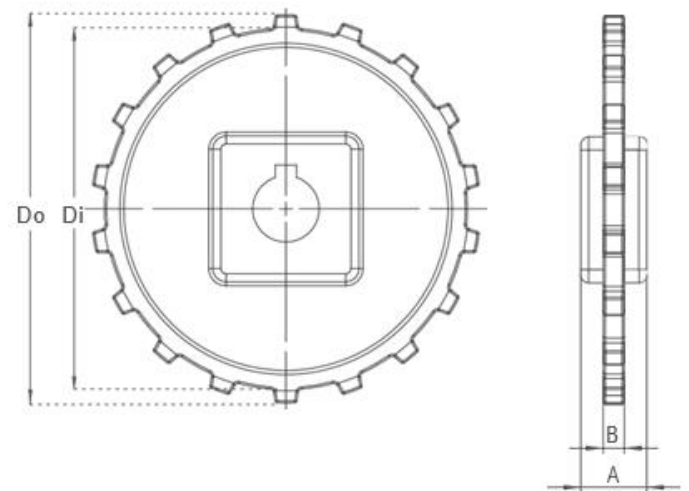
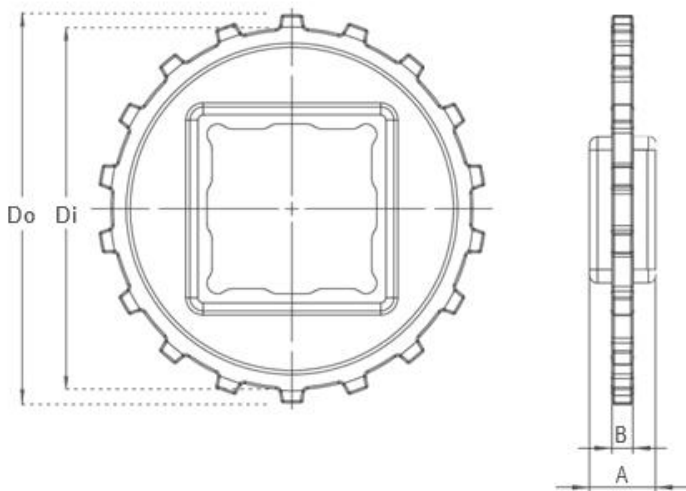

Standard Sprocket Dimensions

NUMBER OF TEETH	Di mm / inch	Do mm / inch	B mm / inch	A mm / inch	Square Bore (Q) mm / inch	Round Bore (R) mm / inch	PRODUCT CODE	
							Square Type (Q)	Round Type (R)
Z8	53,2 / 2,09	64,0 / 2,52	8 / 0,31	25 / 1	25 / 1	25-30 / 1-1.25	FL-XP-25.4SQZ8	FL-XP-25.4SRZ8
Z10	71,6 / 2,82	82,5 / 3,25	8 / 0,31	25 / 1	40 / 1,5	25-30 / 1-1.25	FL-XP-25.4SQZ10	FL-XP-25.4SRZ10
Z12	89,0 / 3,50	99,5 / 3,92	8 / 0,31	25 / 1	40 / 1,5	25-30 / 1-1.25	FL-XP-25.4SQZ12	FL-XP-25.4SRZ12
Z15	114,0 / 4,49	124,0 / 4,88	8 / 0,31	25 / 1	40-60 / 1,5-2,5	25-30 / 1-1.25	FL-XP-25.4SQZ15	FL-XP-25.4SRZ15
Z18	136,4 / 5,37	146,4 / 5,76	8 / 0,31	25 / 1	40-60 / 1,5-2,5	25-30 / 1-1.25	FL-XP-25.4SQZ18	FL-XP-25.4SRZ18

- * Other sprockets and hub sizes are manufactured upon request
- * POM (Polyacetal) and PP (Polypropylene) sprockets are available upon request
- * Machined split sprockets are available for each size



Clamp

Machined Split Sprocket

Moulded Sprocket

Machined Sprocket

Accessories and Technical Specifications

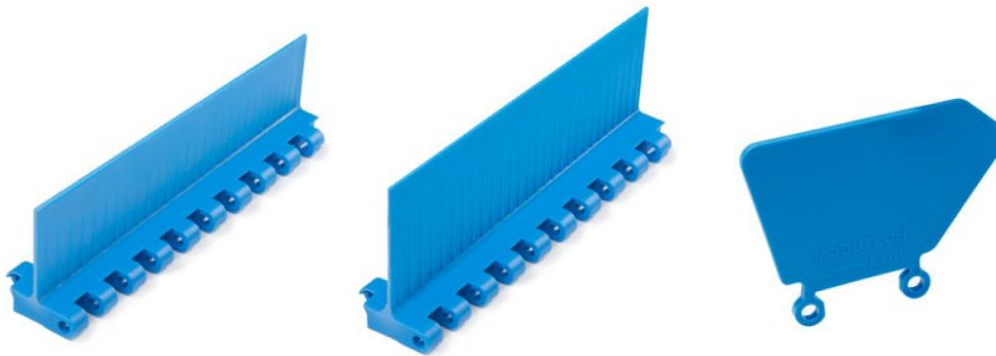

CLEATS AND SIDEWALLS				
Product code	Cleat Height (mm / inch)	Cleat Width (mm / inch)	Product code	Sidewall Height (mm / inch)
FL-T25.XP25.4	25 / 1	152,4 / 6	FL-SW-25.XP25.4	25 / 1
FL-T50.XP25.4	50 / 2	152,4 / 6	FL-SW-50.XP25.4	50 / 2
FL-T75.XP25.4	75 / 3	152,4 / 6	FL-SW-75.XP25.4	75 / 3
FL-T100.XP25.4	100 / 4	152,4 / 6	FL-SW-100.XP25.4	100 / 4

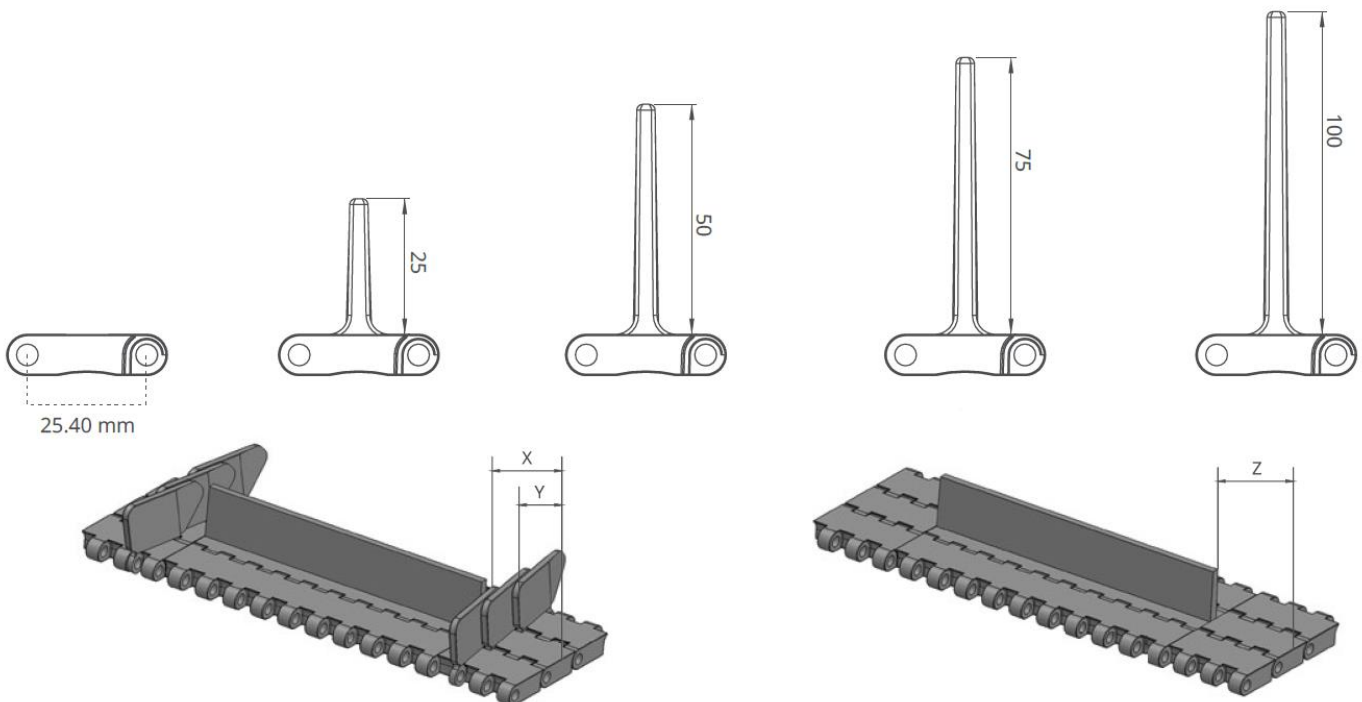

POSSIBLE SIDEWALL FREE ZONE	X		Y	
	mm	inch	mm	inch
Standard, no module cutting	24,0	0,94	15,0	0,59
Module cutting necessary	32,0	1,26	22,0	0,87
Standard, no module cutting	40,0	1,57	30,0	1,18
Module cutting necessary	48,0	1,89	37,0	1,46
Standard, no module cutting	56,0	2,20	45,0	1,77
Module cutting necessary	64,0	2,52	53,0	2,09

POSSIBLE CLEAT FREE ZONE	Z	
	mm	inch
Standard, module cutting	15,0	0,59
Standard, no module cutting	30,0	1,18
Standard, module cutting	45,0	1,77
Standard, module cutting	60,0	2,36
Standard, no module cutting	76,0	2,99

Note: Gap between cleat and sidewall minimum 2-3 mm

Non-standard cleat is upon request

Engineering Information

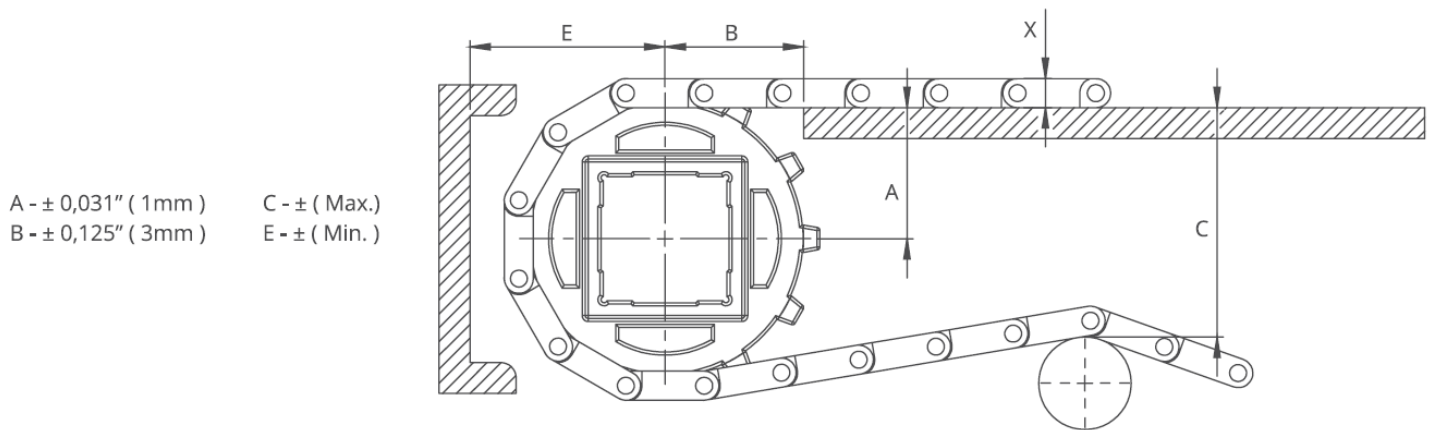

Conveyor Frame Dimensions

SPROCKETS DESCRIPTION		A		B		C		E		X		
Pitch Diameter	Number of teeth	Range (Bottom to Top)		inch	mm	inch	mm	inch	mm	inch	mm	
		inch	mm									
2.32	59,0	8	1,17	29,8	1,44	36,5	1,94	49,3	1,91	48,6	0.35	8,8
2,99	76,0	10	1,47	37,0	1,69	42,9	2,57	65,4	2,21	56,2	0.35	8,8
3,59	91,2	12	1,79	45,5	1,86	47,3	3,19	81,1	2,53	64,3	0.35	8,8
4.65	118,0	15	2,22	56,3	2,13	54,1	4,15	105,3	2,96	75,1	0.35	8,8
5.67	144,0	18	2,71	69,0	2,31	58,7	5,16	131,0	3,45	87,8	0.35	8,8

Slider Support System for Straight Running Belts

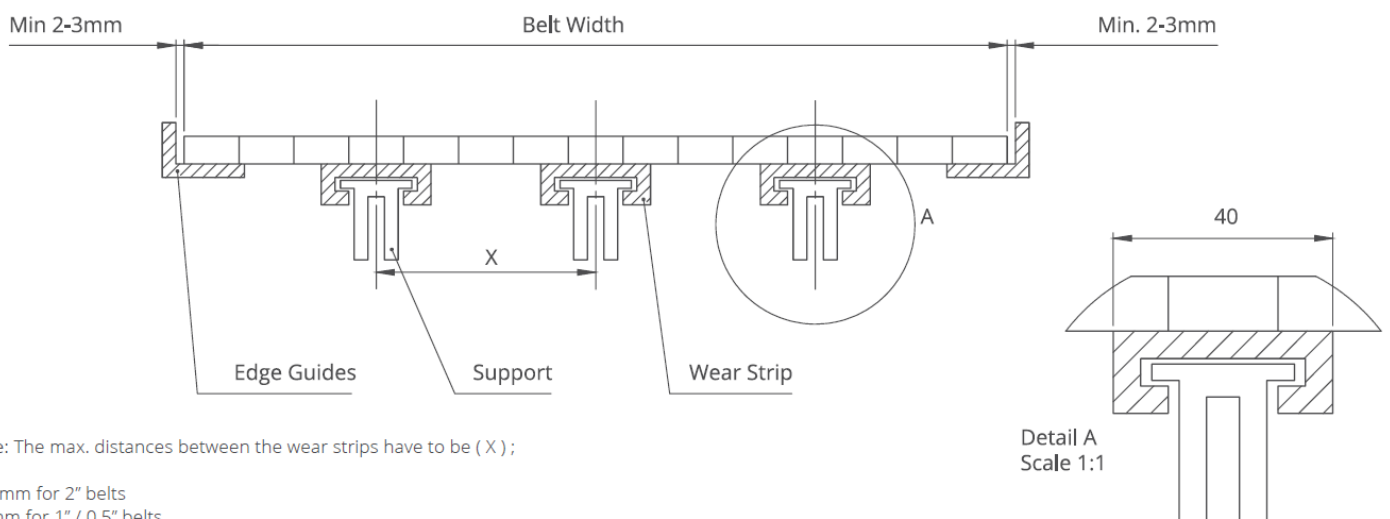

Note: The max. distances between the wear strips have to be (X);

125 mm for 2" belts
80 mm for 1" / 0.5" belts

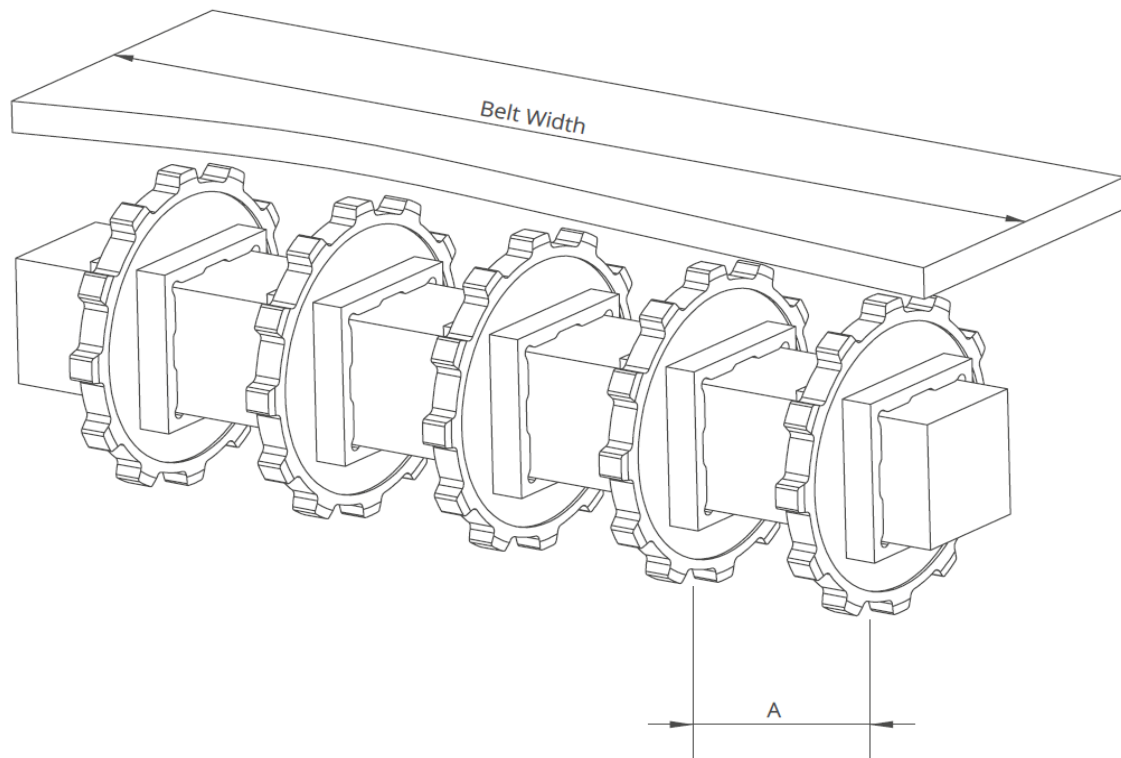

Sprockets Arrangement

Standard Belt Width		Number of sprockets per shaft		A (mm/inch)	
mm	inch	Drive Shaft	Return Shaft	Min.	Max.
152,4	6,0	2	2	60 / 2,36	170 / 6,6
228,6	9,0	2	2	60 / 2,36	170 / 6,6
304,8	12,0	3	2	60 / 2,36	170 / 6,6
381,0	15,0	4	3	60 / 2,36	170 / 6,6
457,2	18,0	5	3	60 / 2,36	170 / 6,6
533,4	21,0	5	3	60 / 2,36	170 / 6,6
609,6	24,0	6	3	60 / 2,36	170 / 6,6
685,8	27,0	6	4	60 / 2,36	170 / 6,6
762,0	30,0	7	4	60 / 2,36	170 / 6,6
838,2	33,0	7	4	60 / 2,36	170 / 6,6
914,4	36,0	8	4	60 / 2,36	170 / 6,6
990,6	39,0	8	5	60 / 2,36	170 / 6,6
1066,8	42,0	9	5	60 / 2,36	170 / 6,6
1143,0	45,0	9	5	60 / 2,36	170 / 6,6
1219,2	48,0	10	5	60 / 2,36	170 / 6,6
1295,4	51,0	10	6	60 / 2,36	170 / 6,6
1371,6	54,0	11	7	60 / 2,36	170 / 6,6
1447,8	57,0	11	7	60 / 2,36	170 / 6,6
1524,0	60,0	12	7	60 / 2,36	170 / 6,6
1600,2	63,0	12	8	60 / 2,36	170 / 6,6
1676,4	66,0	12	8	60 / 2,36	170 / 6,6
1752,6	69,0	13	8	60 / 2,36	170 / 6,6
1828,8	72,0	14	9	60 / 2,36	170 / 6,6
1905,0	75,0	14	9	60 / 2,36	170 / 6,6
1981,2	78,0	15	10	60 / 2,36	170 / 6,6
2057,4	81,0	15	10	60 / 2,36	170 / 6,6

Note: number of sprockets depends on belt load