

FabLink®-EC12.7.GT

Snack Food Applications

Incline - Decline Lines, Container Conveyance

Packaging Applications

Box Incline - Decline Lines

Beverage Applications

Incline - Decline Lines, Filling, Box Transfer

FabLink®-EC12.7.GT

Pitch	12,7 mm / 0.5 inch
Belt surface	Close, friction surface
Minimum width	150 mm / 5.90 inch
Open Area (%)	0%
Cleat	Yes (T25, T50)
Sidewall	No
Pin	Ø 4,7 mm / 0,185 inch – Self lock
Approved	FDA and EU
Curve	No
Color	Additional colors available
Cleanability	Excellent
Belt thickness	12.5 mm / 0.49 inch

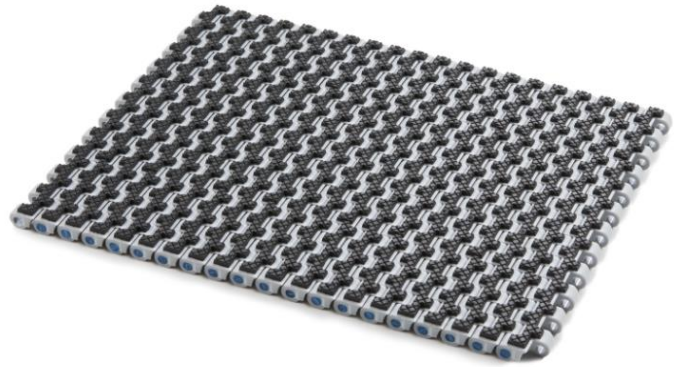

Features and Functional Benefits

Unique rubber top eliminates wear and increases friction in incline-decline applications.
 Minimum nosebar diameter 18 mm.
 Tight transfer applications.

Available Moulded Module Sizes

150 mm / 5.90 inch module

Technical Information

BELT MATERIAL	BELT STRENGTH				TEMPERATURE		BELT WEIGHT Kg/m ² / lb/ft ²
	Straight		Curve		°C / ° F (min.)	°C / ° F (max.)	
	N/mm	lb/ft	N/mm	lb/ft			
Polypropylene (PP)	9900	679	-	-	+5 / +41	+90 / +194	6,5 / 1,33
Polyethylene (PE)	-	-	-	-	-	-	-
Acetal (POM)	-	-	-	-	-	-	-

Standard Belt Widths

WIDTH (W)				BELT WIDTH TOLERANCE (max.)
PP-PE		POM		
mm	inch	mm	inch	
150,0	5.90	-	-	± 1 mm
200,0	7.87	-	-	± 1 mm
250,0	9.84	-	-	± 2 mm
300,0	11.81	-	-	± 2 mm
350,0	13.77	-	-	± 2 mm
400,0	15.75	-	-	± 2 mm
450,0	17.71	-	-	± 2 mm
500,0	19.69	-	-	± 2 mm
550,0	21.65	-	-	± 2 mm
600,0	23.62	-	-	± 3 mm
650,0	25.60	-	-	± 3 mm
700,0	27.56	-	-	± 3 mm
750,0	29.50	-	-	± 3 mm
800,0	31.50	-	-	± 3 mm
850,0	33.46	-	-	± 4 mm
900,0	35.43	-	-	± 4 mm

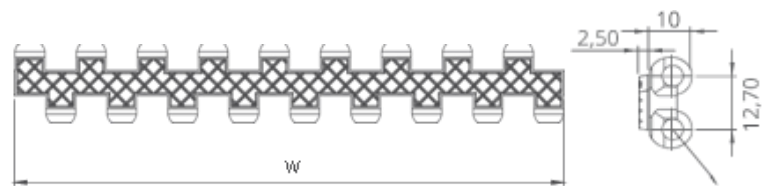

- Standard belt increments 50mm
- Non-standard belt increments 16.6mm

Please contact with customer service for precise belt measurements

Sprockets and Technical Specifications

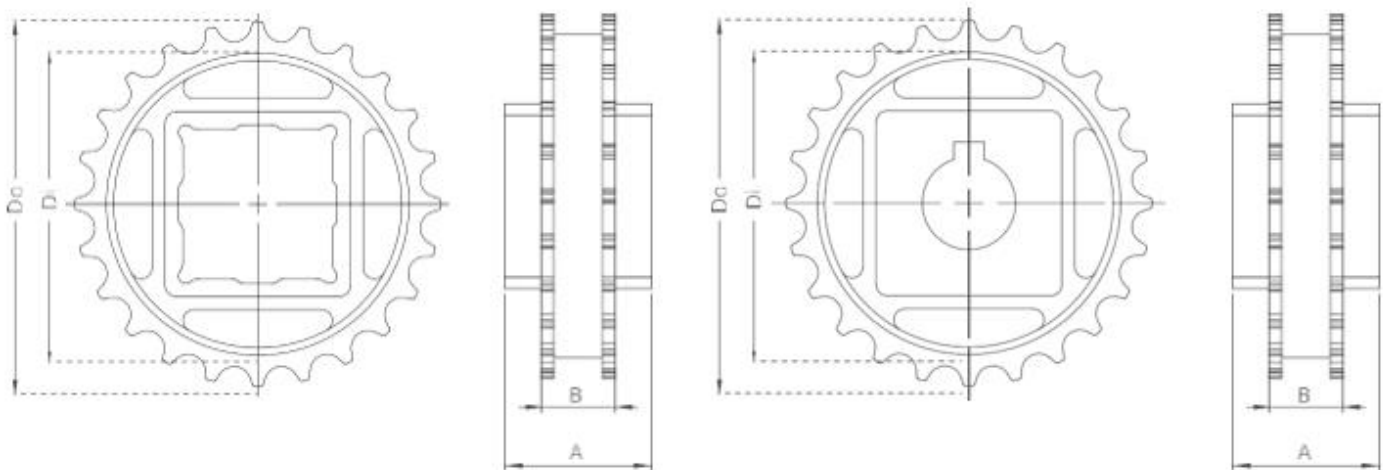
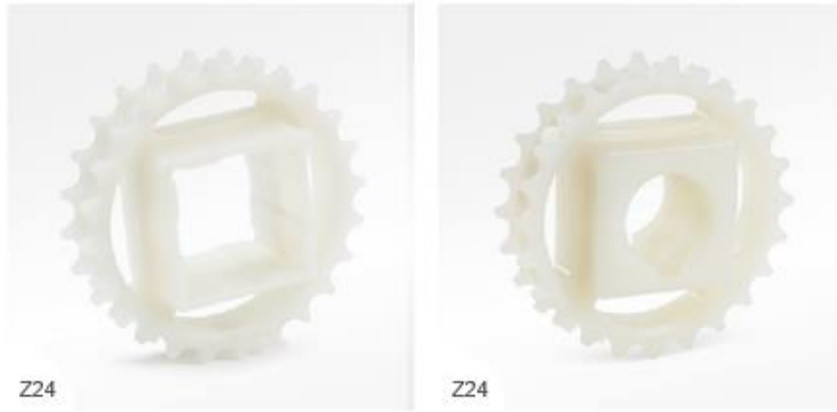

Standard Sprocket Dimensions

NUMBER OF TEETH	Di mm / inch	Do mm / inch	B mm / inch	A mm / inch	Square Bore (Q) mm / inch	Round Bore (R) mm / inch	PRODUCT CODE	
							Square Type (Q)	Round Type (R)
Z19	68,5 / 2.69	78,0 / 2.54	20 / 0.79	40 / 1.57	25-40 / 1-1.5	25-30 / 1-1.25	FL-EC-12.7SQZ19	FL-EC-12.7SRZ19
Z24	88,7 / 3.49	98,8 / 3.89	20 / 0.79	40 / 1.57	25-40 / 1-1.5	25-30 / 1-1.25	FL-EC-12.7SQZ24	FL-EC-12.7SRZ24
Z28	105,0 / 4.13	115,2 / 4.53	20 / 0.79	40 / 1.57	25-40 / 1-1.5	25-30 / 1-1.25	FL-EC-12.7SQZ28	FL-EC-12.7SRZ28
Z30	113,0 / 4.44	123,3 / 4.85	20 / 0.79	40 / 1.57	25-40 / 1-1.5	25-30 / 1-1.25	FL-EC-12.7SQZ30	FL-EC-12.7SRZ30
Z36	137,5 / 5.41	148,0 / 5.82	20 / 0.79	40 / 1.57	25-40 / 1-1.5	25-30 / 1-1.25	FL-EC-12.7SQZ36	FL-EC-12.7SRZ36

Other sprockets and hub sizes are manufactured upon request

- * POM (Polyacetal) and PP (Polypropylene) sprockets are available upon request
- * Machined split sprockets are available for each size

*Machined Split Sprockets are available for each

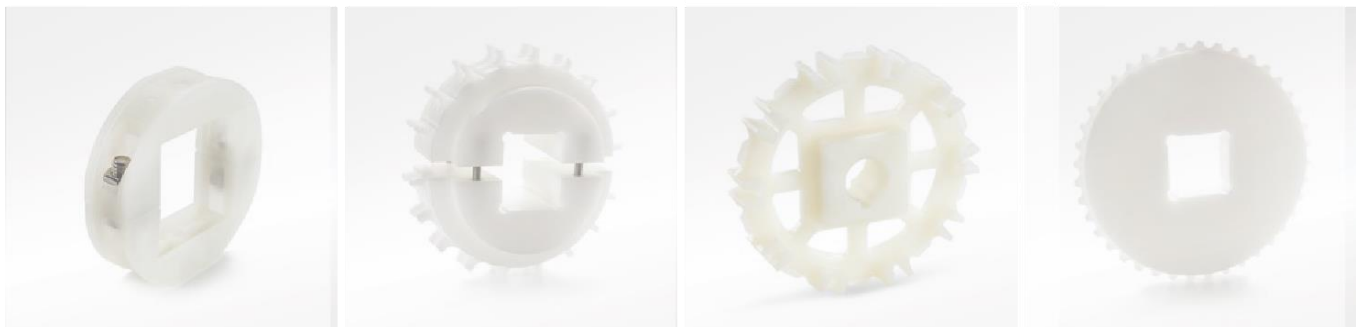

Clamp

Machined Split Sprocket

Moulded Sprocket

Machined Sprocket

Accessories and Technical Specifications



CLEATS AND SIDEWALLS				
Product code	Cleat Height (mm / inch)	Cleat Width (mm / inch)	Product code	Sidewall Height (mm / inch)
FL-EC-12.7.T25	25 / 1	150 / 5.90	-	-
FL-EC-12.7.T25	50 / 2	150 / 5.90	-	-

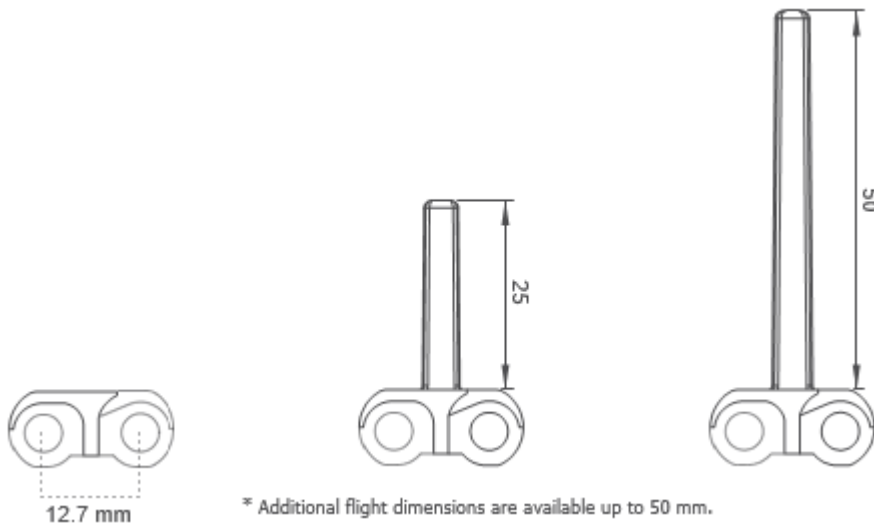

POSSIBLE Cleat Indents	Z	
	mm	inch
Standard, module cutting	33,3	1.31
Standard, no module cutting	50,0	1.97
Standard, module cutting	66,6	2.62
Standard, module cutting	83,3	3.28
Standard, no module cutting	100,0	3.94

Non-standard Cleat is upon request



Engineering Information

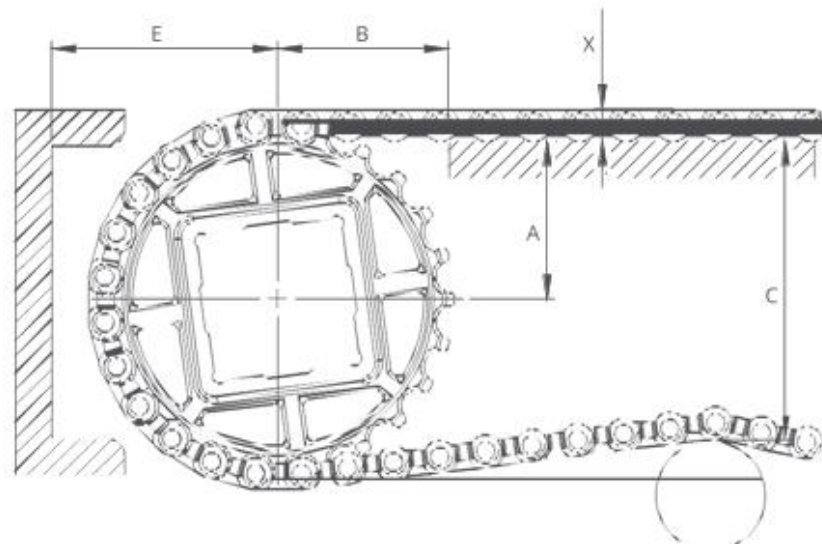

A - $\pm 0,031''$ (1mm) C - \pm (Max.)
 B - $\pm 0,125''$ (3mm) E - \pm (Min.)

Conveyor Frame Dimensions

SPROCKETS DESCRIPTION		A		B		C		E		X		
Pitch Diameter		Range (Bottom to Top)		inch	mm	inch	mm	inch	mm	inch	mm	
inch	mm	inch	mm									
FabLink®-EC12.7.C / FabLink®- EC12.7.FG												
2.89	73,4	19	1.36	34,5	1.67	42,5	2.83	72,0	2.09	53,0	0.39	10,0
3.69	93,8	24	1.73	44,0	1.89	48,0	3.23	82,0	2.48	63,0	0.39	10,0
4.33	110,1	28	2.07	52,5	2.05	52,0	3.86	98,0	2.80	71,0	0.39	10,0
4.66	118,3	30	2.24	57,0	2.13	54,0	4.02	102,0	2.95	75,0	0.39	10,0
5.62	142,7	36	2.72	69,0	2.35	59,8	4.96	126,0	3.43	87,0	0.39	10,0
FabLink®-EC12.7.GT												
2.89	73,4	19	1.46	37,0	1.67	42,5	2.83	72,0	2.19	55,5	0.49	12,5
3.69	93,8	24	1.83	46,5	1.89	48,0	3.23	82,0	2.58	65,5	0.49	12,5
4.33	110,1	28	2.17	55,0	2.05	52,0	3.86	98,0	2.89	73,5	0.49	12,5
4.66	118,3	30	2.34	59,5	2.13	54,0	4.02	102,0	3.05	77,5	0.49	12,5
5.62	142,7	36	2.81	71,5	2.35	59,8	4.96	126,0	3.52	89,5	0.49	12,5

Slider Support System for Straight Running Belts

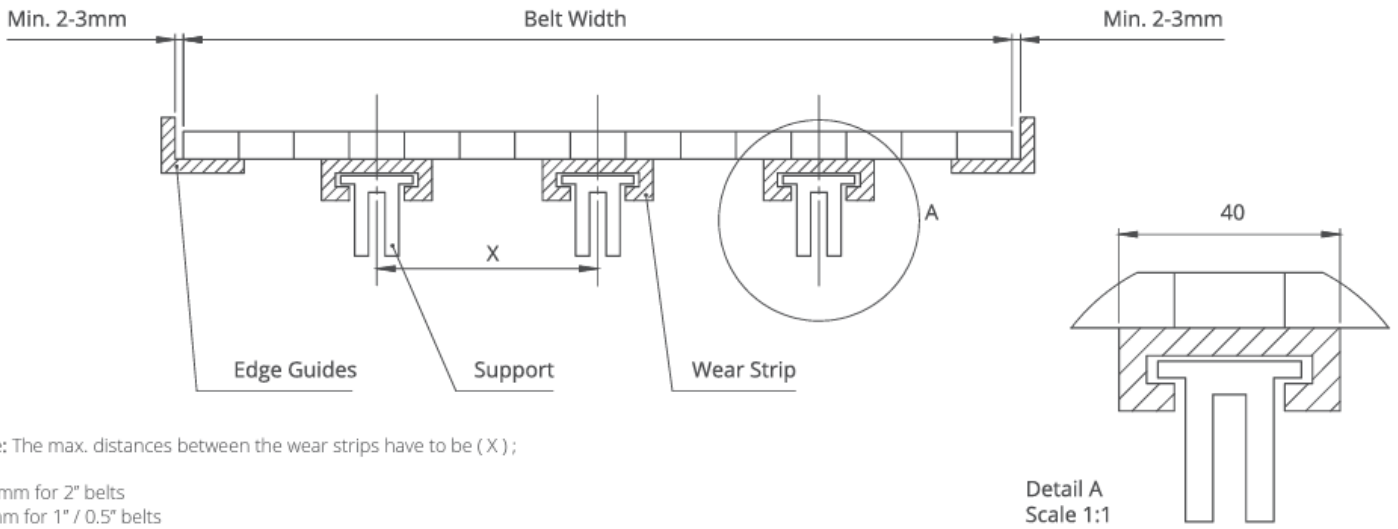

Note: The max. distances between the wear strips have to be (X);

125 mm for 2" belts
80 mm for 1" / 0.5" belts

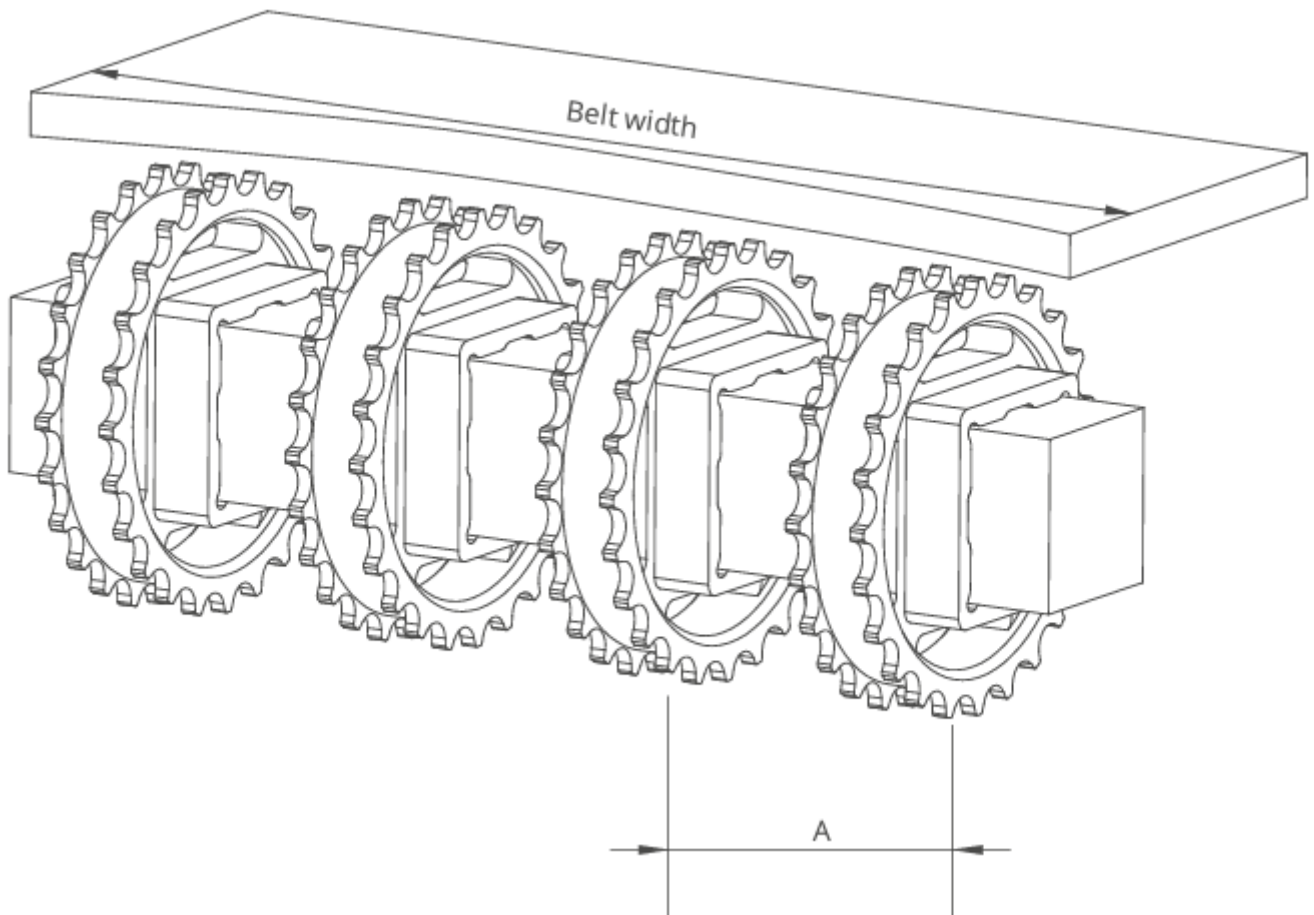

Sprockets Arrangement

Standard Belt Width		Number of sprockets per shaft		A (mm/inch)	
mm	inch	Drive Shaft	Return Shaft	Min.	Max.
150,0	5.91	2	2	50 / 2.00	100 / 4.00
200,0	7.87	3	2	50 / 2.00	100 / 4.00
250,0	9.84	3	2	50 / 2.00	100 / 4.00
300,0	11.81	4	3	50 / 2.00	100 / 4.00
350,0	13.78	4	3	50 / 2.00	100 / 4.00
400,0	15.75	5	3	50 / 2.00	100 / 4.00
450,0	17.72	5	3	50 / 2.00	100 / 4.00
500,0	19.69	6	4	50 / 2.00	100 / 4.00
550,0	21.65	7	4	50 / 2.00	100 / 4.00
600,0	23.62	7	4	50 / 2.00	100 / 4.00
650,0	25.59	7	4	50 / 2.00	100 / 4.00
700,0	27.56	8	5	50 / 2.00	100 / 4.00
750,0	29.53	9	6	50 / 2.00	100 / 4.00
800,0	31.50	9	6	50 / 2.00	100 / 4.00
850,0	33.46	10	7	50 / 2.00	100 / 4.00
900,0	35.43	11	7	50 / 2.00	100 / 4.00
950,0	37.40	11	7	50 / 2.00	100 / 4.00
1000,0	39.37	11	7	50 / 2.00	100 / 4.00
1050,0	41.34	11	7	50 / 2.00	100 / 4.00
1100,0	43.31	12	7	50 / 2.00	100 / 4.00
1150,0	45.28	12	7	50 / 2.00	100 / 4.00
1200,0	47.24	12	7	50 / 2.00	100 / 4.00
1250,0	49.21	13	8	50 / 2.00	100 / 4.00
1300,0	51.18	13	8	50 / 2.00	100 / 4.00
1350,0	53.15	13	8	50 / 2.00	100 / 4.00
1400,0	55.12	14	8	50 / 2.00	100 / 4.00