



## **FabLink®-EC50.8.NT**

### **Meat Applications**

Slaughtering / Evisceration, Cutting Lines, Deboning Lines, Bone Takeaway, Dressing Lines, Trim Lines

### **Poultry Applications**

Live Birds, Slaughtering / Evisceration, Skining, Cut-up, Chiller Discharge, Bird Accumulation, Freezing Lines, Elevators

### **Sea Food Applications**

Trim Lines, Control Tables, Glazing, Elevators

### **Fruits and Vegetables Applications**

Bulk Feeding, Elevators, Control Sorting Table, Filling

# FabLink® EC50.8.NT

Pitch	50.8 mm / 2 inch
Belt surface	Open, Nub Top Surface
Minimum width	200 mm / 7.87 inch
Open Area (%)	0%
Cleat	Yes ( T25, T50, T75, T100, T150, TNC50, TNC100, TC75, TC100, TC150, TCC75, TCC100, TCC150, TCCH100)
Sidewall	Yes ( h=25 mm, h=50 mm, h=75 mm, h=100 mm )
Pin	∅ 7 mm / 0,275 inch – Self lock
Approved	FDA and EU
Curve	No
Color	Additional colors available
Cleanability	Excellent
Belt thickness	18.5 mm / 0.728 inch



## Product Features and Functional Benefits

- Easy to clean reduces downtime for cleaning time 70%.
- Close, sticky transfer applications. Non-adhesive due to reduced contact surface.
- Reduces bacteria growth.
- Unique sprocket engagement - higher Product load and longer conveyors.
- Strong and thick Product supports allow more load without breaking.
- Impact resistance to withstand heavy objects falling into the belt.

## Available Moulded Module Sizes

- 200 mm / 7.87 inch module
- 200 mm / 7.87 inch edge module with 40 mm indent

## Technical Information

BELT MATERIAL	BELT STRENGTH				TEMPERATURE		BELT WEIGHT Kg/m <sup>2</sup> / lb/ft <sup>2</sup>
	Straight		Curve		°C / ° F (min.)	°C / ° F (max.)	
	N/mm	lb/ft	N/mm	lb/ft			
PP (Polypropylene)	-	-	-	-	-	-	-
PE (Polyethylene)	11000	753	-	-	-73 / -99	+66 / +150.8	9,6 - 1.97
Acetal	33000	2260	-	-	-43 / -45	+110 / +230	13,9 - 2.85

Belt strength and temperature values are maximum on the table

## Standard Belt Widths

WIDTH (W)				BELT WIDTH TOLERANCE (max.)
PP-PE		POM		
mm	inch	mm	inch	
200,0	7.87	200,0	7.87	± 1 mm
300,0	11.81	300,0	11.81	± 2 mm
400,0	15.75	400,0	15.75	± 2 mm
500,0	19.69	500,0	19.69	± 2 mm
600,0	23.62	600,0	23.62	± 3 mm
700,0	27.56	700,0	27.56	± 3 mm
800,0	31.50	800,0	31.50	± 3 mm
900,0	35.43	900,0	35.43	± 4 mm
1000,0	39.37	1000,0	39.37	± 4 mm
1100,0	43.31	1100,0	43.31	± 4 mm
1200,0	47.24	1200,0	47.24	± 4 mm
1300,0	51.18	1300,0	51.18	± 5 mm
1400,0	55.11	1400,0	55.11	± 5 mm
1500,0	59.06	1500,0	59.06	± 5 mm

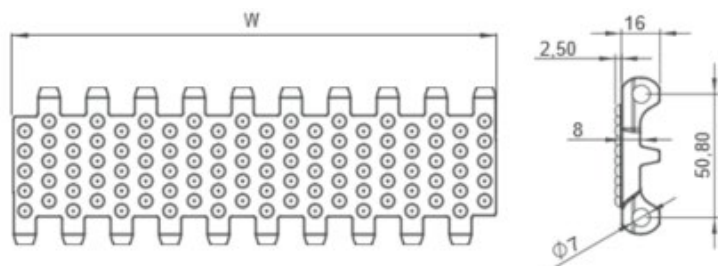

- Standard belt increments 100 mm
  - Non-standard belt increments 20mm
- Please contact with customer service for precise belt measurements

## Sprockets and Technical Specifications

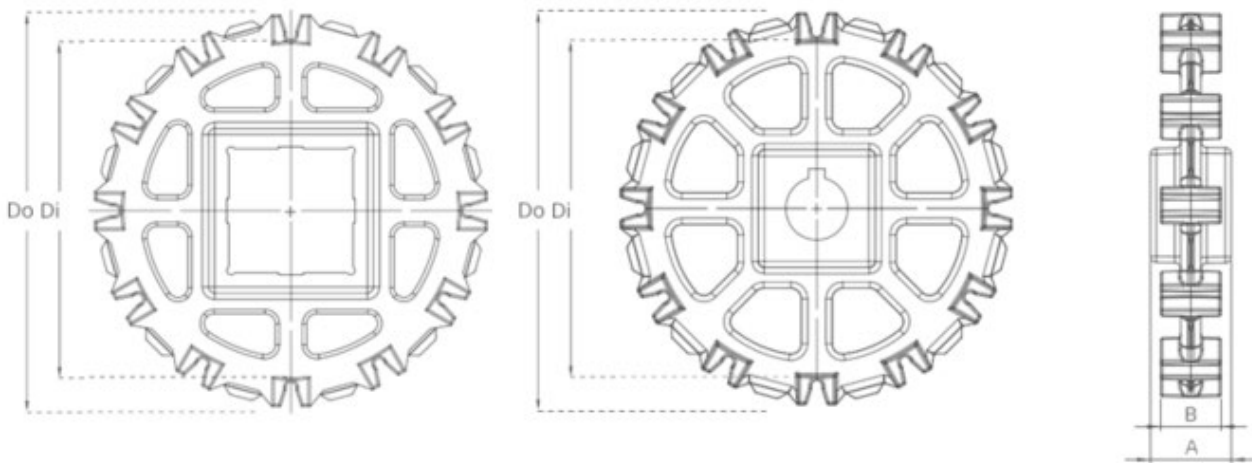

### Standard Sprocket Dimensions

NUMBER OF TEETH	Di mm / inch	Do mm / inch	B mm / inch	A mm / inch	Square Bore (Q) mm / inch	Round Bore (R) mm / inch	PRODUCT CODE	
							Square Type (Q)	Round Type (R)
Z6	73,0 / 2.87	90,0 / 3.54	30 / 1.18	40 / 1.57	40 / 1.5	25-30 / 1-1.25	FL-EC-508SQZ6	FL-EC-508SRZ6
Z8	107,5 / 4.23	124,5 / 4.90	30 / 1.18	40 / 1.57	40 / 1.5	25-30 / 1-1.25	FL-EC-508SQZ8	FL-EC-508SRZ8
Z10	141,5 / 5.57	158,0 / 6.22	30 / 1.18	40 / 1.57	40-60 / 1.5-2.5	25-30 / 1-1.25	FL-EC-508SQZ10	FL-EC-508SRZ10
Z12	175,2 / 6.90	191,2 / 7.53	30 / 1.18	40 / 1.57	40-60 / 1.5-2.5	25-30 / 1-1.25	FL-EC-508SQZ12	FL-EC-508SRZ12

- \* Other sprockets and hub sizes are manufactured upon request
- \* POM (Acetal) and PP (Polypropylene) sprockets are available upon request

\*Machined Split Sprockets are available for each size

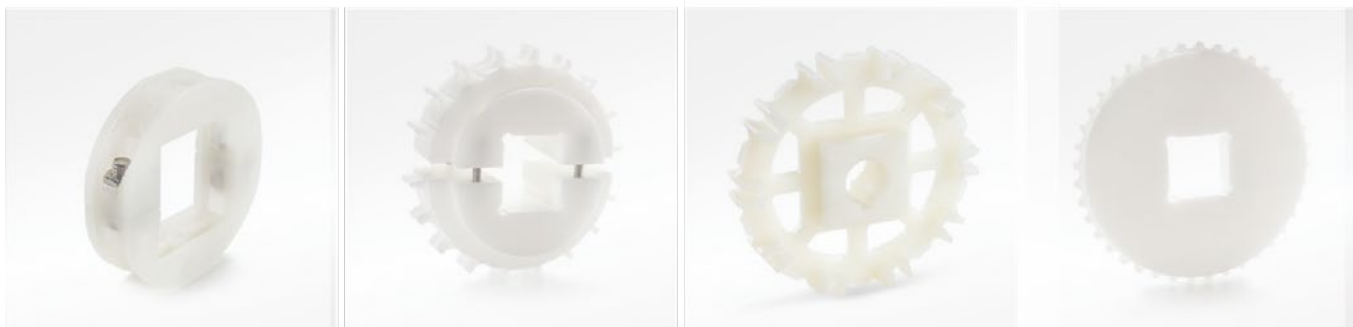

Clamp

Machined Split Sprocket

Moulded Sprocket

Machined Sprocket

Accessories and Technical Specifications



Cleats and sidewalls

Product code	Cleat Height (mm / inch)	Cleat Width (mm / inch)	Product code	Sidewall Height (mm / inch)
FL-EC-508T25	25 / 1	200 / 7.87	FL-EC-508SW25	25 / 1
FL-EC-508T50	50 / 2	200 / 7.87	FL-EC-508SW50	50 / 2
FL-EC-508T75	75 / 3	200 / 7.87	FL-EC-508SW75	75 / 3
FL-EC-508T100	100 / 4	200 / 7.87	FL-EC-508SW100	100 / 4
FL-EC-508T150	150 / 6	200 / 7.87	-	-
FL-EC-508TC75	75 / 3	200 / 7.87	-	-
FL-EC-508TC100	100 / 4	200 / 7.87	-	-
FL-EC-508TC150	150 / 6	200 / 7.87	-	-
FL-EC-508TCC75	75 / 3	200 / 7.87	-	-
FL-EC-508TCC100	100 / 4	200 / 7.87	-	-
FL-EC-508TCC150	150 / 6	200 / 7.87	-	-
FL-EC-508TNC100	100 / 4	200 / 7.87	-	-
FL-EC-508TCH100	100 / 4	200 / 7.87	-	-
FL-EC-508TCCH100	100 / 4	200 / 7.87	-	-

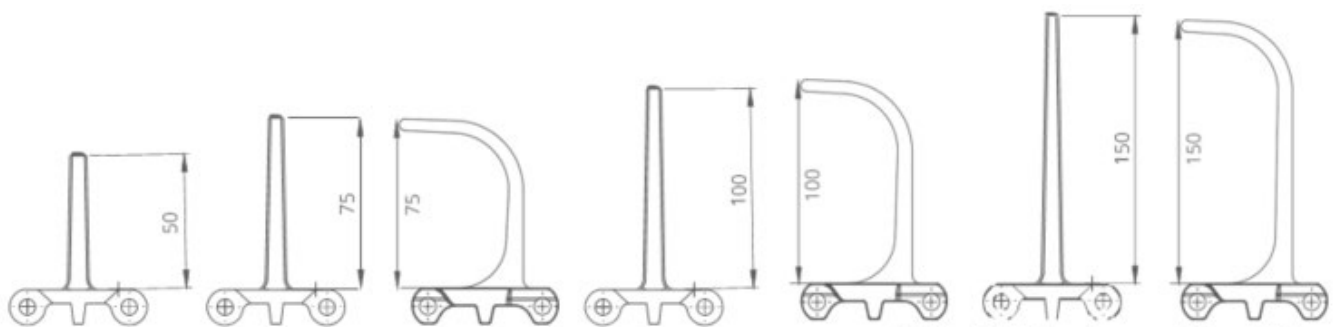

\* Additional flight dimensions are available up to 150 mm.

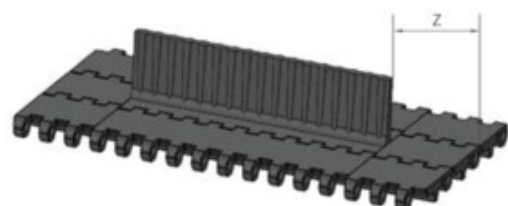
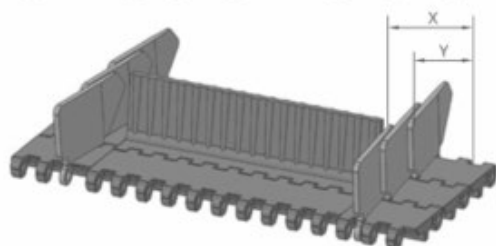

POSSIBLE SIDEWALL and Cleat Indents	X		Y	
	mm	inch	mm	inch
Standard, no module cutting	32,0	1.26	20,0	0.79
Module cutting necessary	42,0	1.65	30,0	1.18
Standard, no module cutting	52,0	2.05	40,0	1.57
Module cutting necessary	62,0	2.44	50,0	1.97
Standard no module cutting	72,0	2.83	60,0	2.36
Module cutting necessary	82,0	3.23	70,0	2.76

POSSIBLE Cleats Indents	Z	
	mm	inch
Standard, no module cutting	40,0	1.57
Standard, no module cutting	60,0	2.36
Standard, module cutting	80,0	3.15
Standard, no module cutting	100,0	3.94

Note: Gap between Cleat and sidewall minimum 2-3 mm

Non-standard cleat is upon request

### Engineering Information

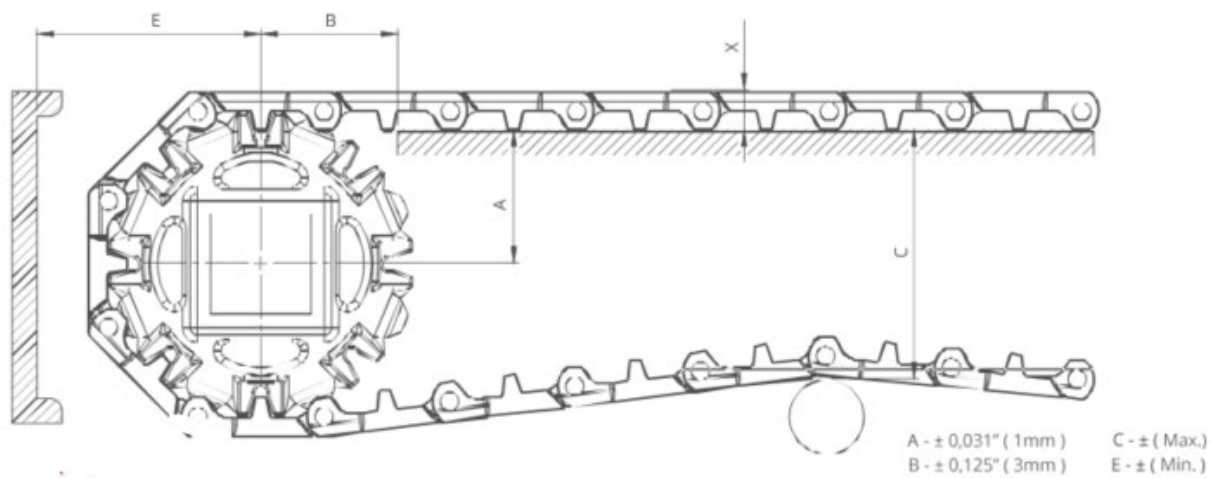

### Conveyor Frame Dimensions

SPROCKETS DESCRIPTION			A		B		C		E		X	
Pitch Diameter		Number of teeth	Range (Bottom to Top)		inch	mm	inch	mm	inch	mm	inch	mm
inch	mm		inch	mm								
3.23	82,0	6	1.70	43,3	1.72	43,8	2.92	74,3	2.73	69,3	0.63	16,0
4.57	116,0	8	2.34	59,4	2.08	52,7	4.23	107,4	3.36	85,4	0.63	16,0
5.91	150,0	10	2.96	75,3	2.38	60,5	5.52	140,3	3.99	101,3	0.63	16,0
7.23	183,6	12	3.65	92,8	2.58	65,5	6.87	174,6	4.68	118,8	0.63	16,0
3.23	82,0	6	1.70	43,3	1.72	43,8	2.92	74,3	2.73	69,3	0.67	17,0
4.57	116,0	8	2.34	59,4	2.08	52,7	4.23	107,4	3.36	85,4	0.67	17,0
5.91	150,0	10	2.96	75,3	2.38	60,5	5.52	140,3	3.99	101,3	0.67	17,0
7.23	183,6	12	3.65	92,8	2.58	65,5	6.87	174,6	4.68	118,8	0.67	17,0
3.23	82,0	6	1.70	43,3	1.72	43,8	2.83	71,8	2.83	71,8	0.73	18,5
4.57	116,0	8	2.34	59,4	2.08	52,7	4.13	104,9	3.46	87,9	0.73	18,5
5.91	150,0	10	2.96	75,3	2.38	60,5	5.43	137,8	4.09	103,8	0.73	18,5
7.23	183,6	12	3.65	92,8	2.58	65,5	6.78	172,1	4.78	121,3	0.73	18,5

## Slider Support System for Straight Running Belts

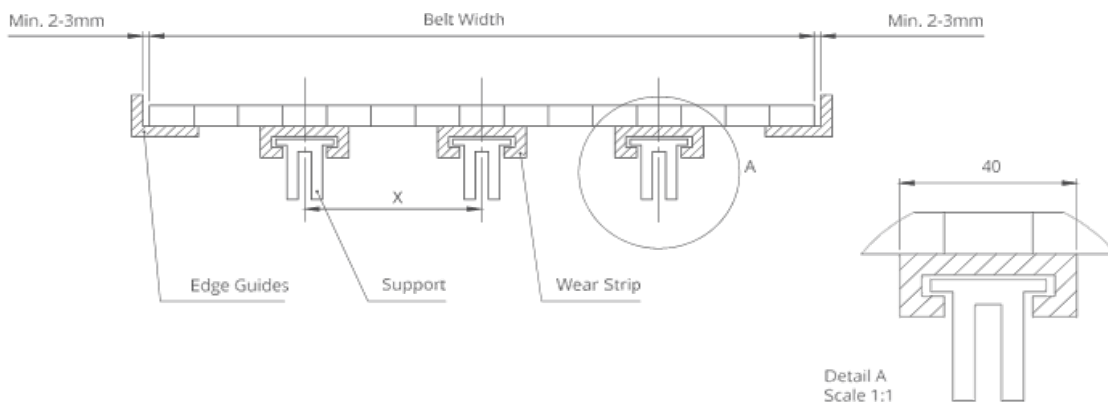

Note: The max. distances between the wear strips have to be ( X ) ;

125 mm for 2" belts  
80 mm for 1" / 0.5" belts

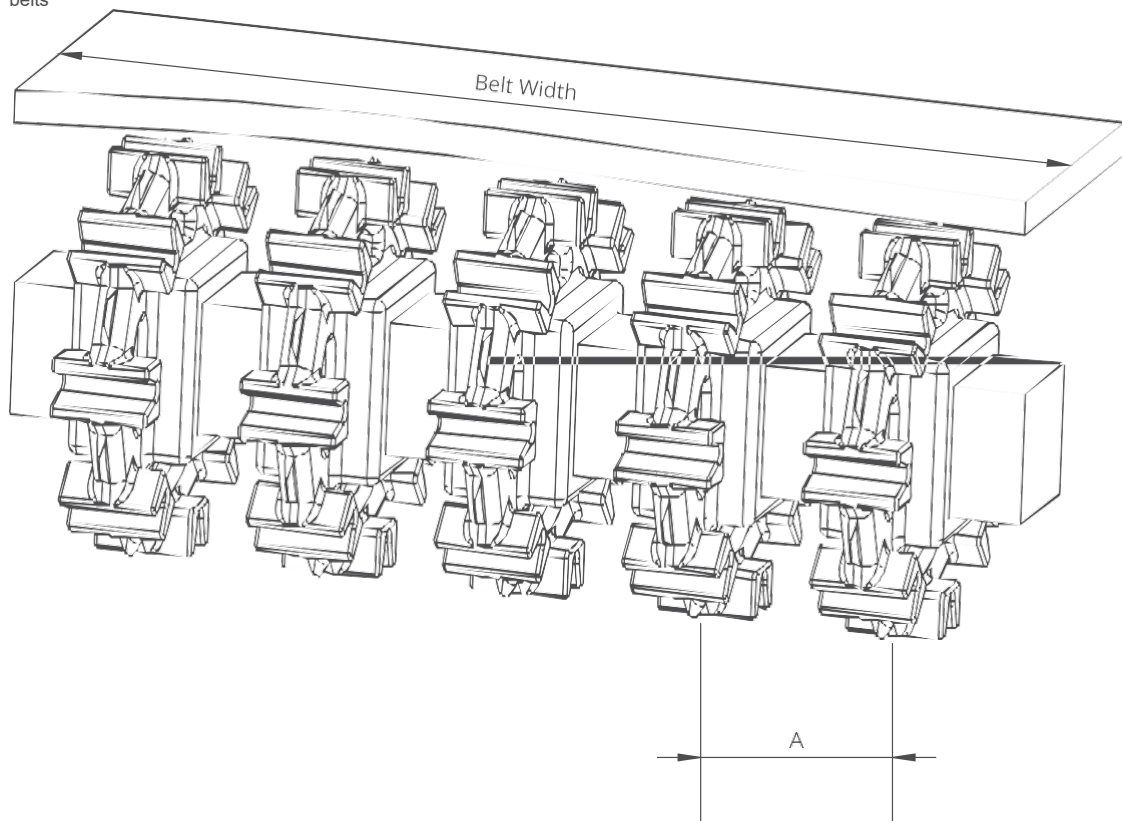

## Sprockets Arrangement

Standard Belt Width		Number of sprockets per shaft		A (mm/inch)	
mm	inch	Drive Shaft	Return Shaft	Min.	Max.
200,0	7.9	2	2	60 / 2.36	150 / 5.9
300,0	11.8	3	2	60 / 2.36	150 / 5.9
400,0	15.7	3	3	60 / 2.36	150 / 5.9
500,0	19.7	4	3	60 / 2.36	150 / 5.9
600,0	23.6	4	3	60 / 2.36	150 / 5.9
700,0	27.6	5	4	60 / 2.36	150 / 5.9
800,0	31.5	6	4	60 / 2.36	150 / 5.9
900,0	35.4	6	5	60 / 2.36	150 / 5.9
1000,0	39.4	7	5	60 / 2.36	150 / 5.9
1100,0	43.3	7	5	60 / 2.36	150 / 5.9
1200,0	47.2	8	6	60 / 2.36	150 / 5.9
1400,0	55.1	9	7	60 / 2.36	150 / 5.9
1600,0	63.0	10	7	60 / 2.36	150 / 5.9
1800,0	70.9	11	8	60 / 2.36	150 / 5.9
2000,0	78.7	12	8	60 / 2.36	150 / 5.9
2200,0	86.6	13	9	60 / 2.36	150 / 5.9
2400,0	94.5	14	10	60 / 2.36	150 / 5.9
2600,0	102.4	15	10	60 / 2.36	150 / 5.9
2800,0	110.2	16	11	60 / 2.36	150 / 5.9
3000,0	118.1	17	12	60 / 2.36	150 / 5.9

Note: Number of sprockets depends on the belt load.