



FabLink[®]-MP.8.0.FG

Bakery Applications

Row Dough Handling, Divider, Proofer Lines, Laminating Lines

Meat Applications

Transfer - Crossover Conveyance and Metal Detectors

Seafood Applications

Grading Lines and Weighing Lines

Fruits and Vegetables Applications

Control and Sorting Tables

Snack Food Applications

Cooling Lines

Beverage Applications

Box Transfer

FabLink®-MP.8.0.FG

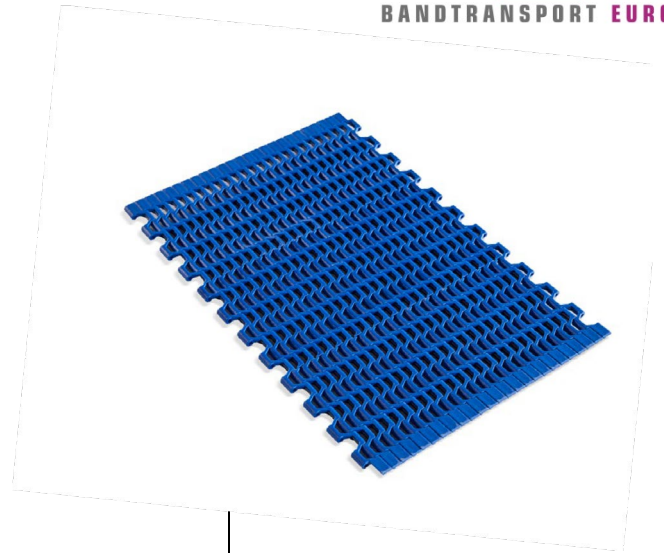

Pitch	8 mm / 0.315 inch
Belt surface	Open, Smooth surface
Minimum width	101.6 mm / 4 inch
Open Area (%)	34% (Biggest opening)
Cleat	No
Sidewall	No
Pin	Ø 3 mm / 0,118 inch
Approved	FDA and EU
Curve	No
Color	Additional colors available
Cleanability	Good
Belt thickness	6 mm / 0,236 inch
Min. Nosebar Diameter	6 mm / 0.236 inch

Product Features and Functional Benefits

- Micro pitch series with small transfer gaps for tight transfer.
- Designed to run over nosebars/knife edges or rollers with a radius down to 3mm (0.12 inch) allowing, precise transfer of even the smallest products.
- Versatile for conveying, drying and cooling applications.
- Optimal design of sprocket teeth, and belt underside provides superior sprocket engagement, safe belt tracking and favorable cleanability.
- Headless pin making it very easy to install and remove the belt for maintenance.

Available Moulded Module Sizes

- 203,2 mm / 8 inch module
- 101,6 mm / 4 inch module

Technical Information

BELT MATERIAL	BELT STRENGTH				TEMPERATURE		BELT WEIGHT Kg/m ² / lb/ft ²
	Straight		Curve		°C / ° F (min.)	°C / ° F (max.)	
	N/mm	lb/ft	N/mm	lb/ft			
Acetal	2650	181	-	-	-43 / -45	+110 / +230	4,4 / 0.90

Standard Belt Widths

WIDTH (W)				BELT WIDTH TOLERANCE (max.)
PP-PE		POM		
mm	inch	mm	inch	
-	-	101,6	4.0	± 1 mm
-	-	203,2	8.0	± 1 mm
-	-	304,8	12.0	± 1 mm
-	-	406,4	16.0	± 1 mm
-	-	508,0	20.0	± 2 mm
-	-	609,6	24.0	± 2 mm
-	-	711,2	28.0	± 2 mm
-	-	812,8	32.0	± 2 mm
-	-	914,4	36.0	± 2 mm

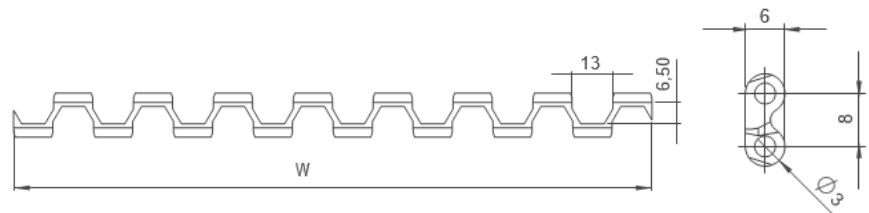

- Standard belt increments 101.6mm
- Non-standard belt increments 25.4mm
- Please contact with customer service for precise belt measurements

Sprockets and Technical Specifications

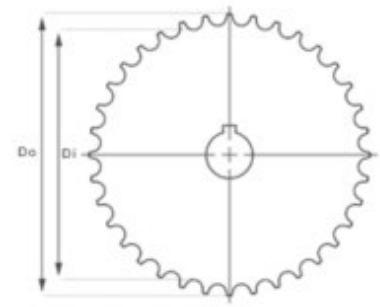
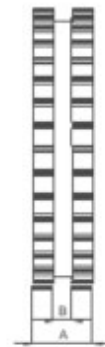
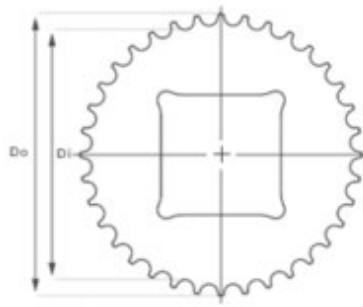

Standard Sprocket Dimensions

NUMBER OF TEETH	Di mm / inch	Do mm / inch	B mm / inch	A mm / inch	Square Bore (Q) mm / inch	Round Bore (R) mm / inch	PRODUCT CODE	
							Square Type (Q)	Round Type (R)
Z18	40,9 / 1.61	48,0 / 1.89	6 / 0.23	20 / 0.78	20 / 0.78	25 / 1	FL-MP-80SQZ18	FL-MP-80SRZ18
Z24	56,4 / 2.22	63,7 / 2.51	6 / 0.23	20 / 0.78	25 / 1	25-30 / 1-1.25	FL-MP-80SQZ24	FL-MP-80SRZ24
Z36	87,5 / 3.44	94,9 / 3.74	6 / 0.23	20 / 0.78	40 / 1.57	25-30 / 1-1.25	FL-MP-80SQZ36	FL-MP-80SRZ36

- *All required sprockets produced by CNC.
- *Other sprockets and hub sizes are manufactured up to request.
- *POM (Acetal) and PA (Polyamide) sprockets raw material is available on request.
- *Machined Split Sprockets are available for each size.



Precise transfer even the smallest products!
Micropitch belt series are suitable to run 6 mm nosebar roller.

Engineering Information

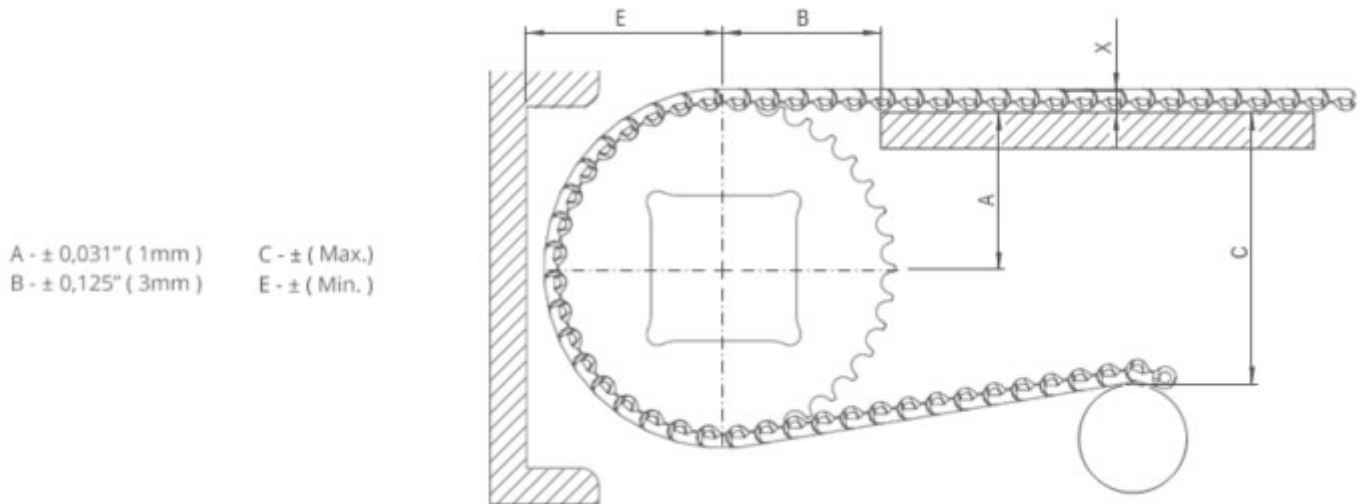

Conveyor Frame Dimensions

SPROCKETS DESCRIPTION		A		B		C		E		X		
Pitch Diameter		Number of teeth	Range (Bottom to Top)		inch	mm	inch	mm	inch	mm	inch	mm
inch	mm		inch	mm								
1.85	47,0	18	0.81	20,5	1.18	30,0	1.12	28,5	1.24	31,5	0.24	6,0
1.95	49,5	24	1.11	28,3	1.38	35,0	1.73	44,0	1.55	39,3	0.24	6,0
3.68	93,5	36	1.72	43,8	1.77	45,0	2.95	75,0	2.16	54,8	0.24	6,0

Slider Support System for Straight Running Belts

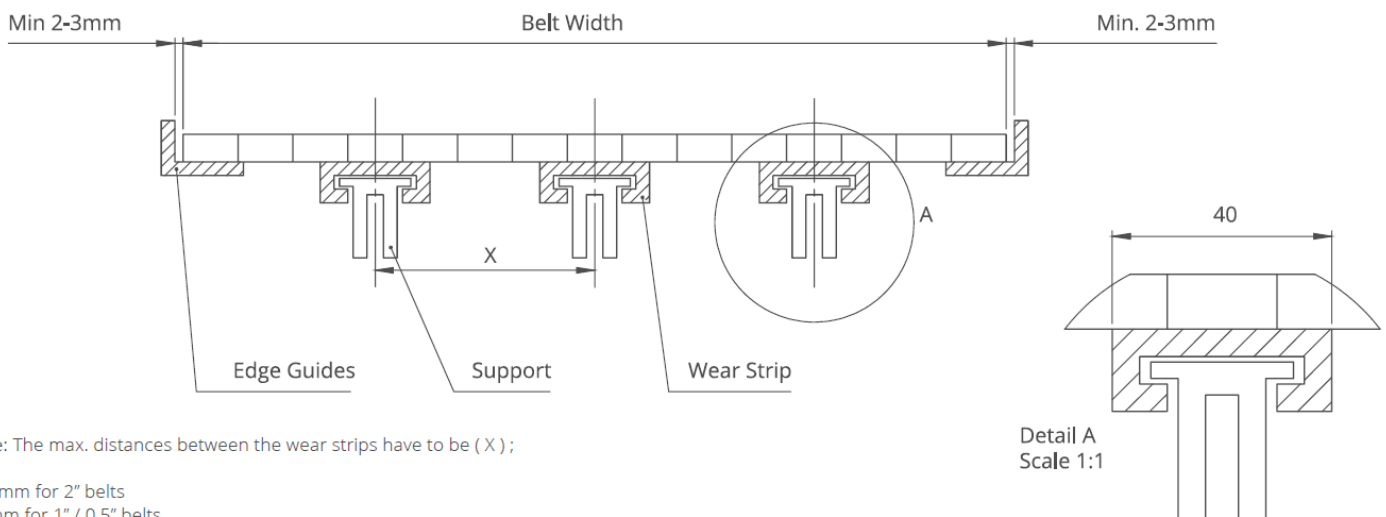

Note: The max. distances between the wear strips have to be (X) :

125 mm for 2" belts
80 mm for 1" / 0.5" belts

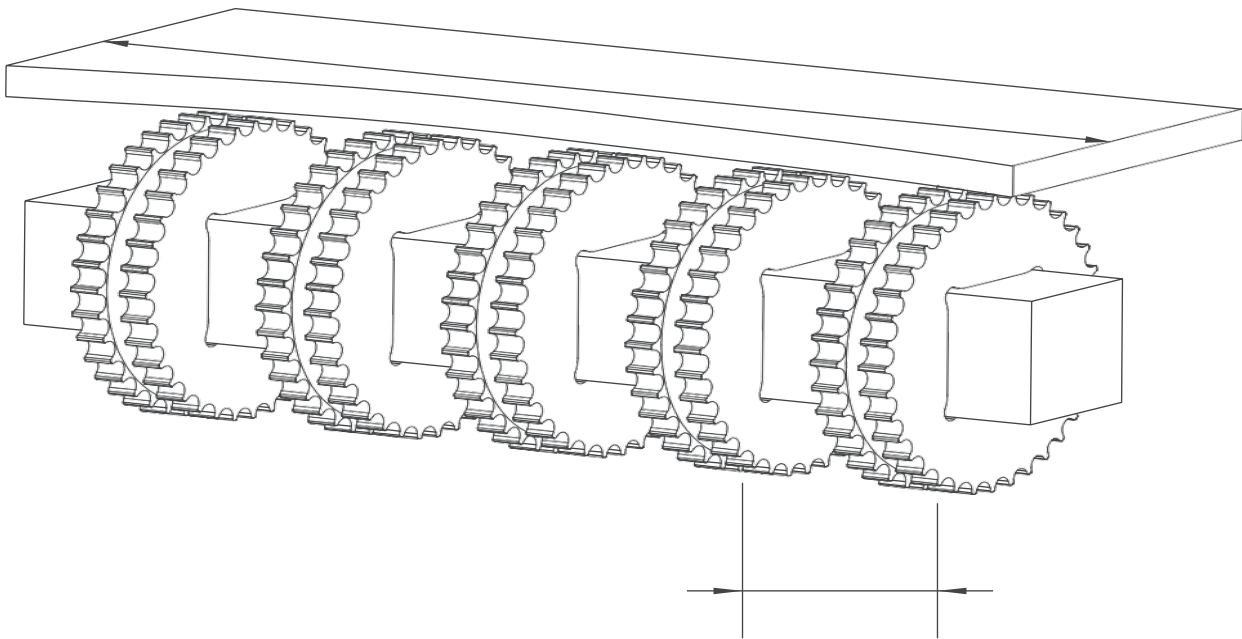

Sprockets Arrangement

Standard Belt Width		Number of sprockets per shaft		A (mm/inch)	
mm	inch	Drive Shaft	Return Shaft	Min.	Max.
101,6	4.0	2	2	50 / 2	100 / 4
203,2	8.0	3	2	50 / 2	100 / 4
304,8	12.0	4	3	50 / 2	100 / 4
406,4	16.0	5	3	50 / 2	100 / 4
508,0	20.0	6	4	50 / 2	100 / 4
609,6	24.0	7	5	50 / 2	100 / 4
711,2	28.0	8	6	50 / 2	100 / 4
812,8	32.0	9	7	50 / 2	100 / 4
914,4	36.0	10	8	50 / 2	100 / 4
1016,0	40.0	11	9	50 / 2	100 / 4
1117,6	44.0	12	9	50 / 2	100 / 4
1219,2	48.0	13	10	50 / 2	100 / 4
1320,8	52.0	14	11	50 / 2	100 / 4
1422,4	56.0	14	11	50 / 2	100 / 4
1524,0	60.0	15	12	50 / 2	100 / 4
1625,6	64.0	16	12	50 / 2	100 / 4

Note: number of sprockets depends on belt load