



FabLink[®]-MD25.4.RR

Fruits and Vegetables

Palletizing / Depalletizing, Sterilization Conveyance

Automotive

Battery Filling

Tire Manufacturing

Dip Tank

Packaging

Accumulation, Palletizing / Depalletizing

Beverages

Glass Palletizing / Depalletizing, Pasteurizers

Pasta

Blanchers, Pasteurizers, Cooling Lines

Meat

Microwaves, Cooling and Freezing Lines

FabLink®-MD25.4.RR

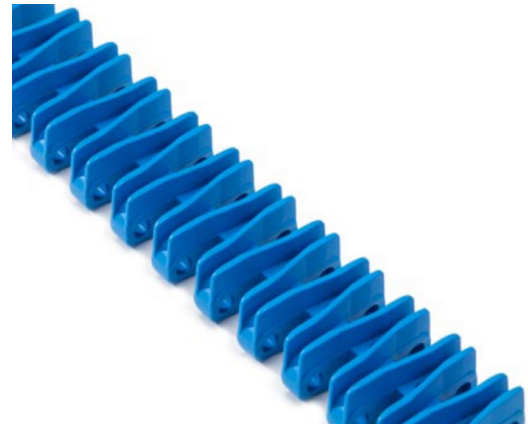

Pitch	25.4 mm / 1 inch
Belt surface	Close, Raised Rib Surface
Minimum width	50 mm / 1.97 inch
Open Area (%)	33% (Biggest opening 5,5 x 7mm)
Cleat	No
Sidewall	No
Pin	Ø 5 mm / 0,197 inch
Approved	FDA and EU
Curve	No
Color	Additional colors available
Cleanability	Good
Belt thickness	16 mm / 0,630 inch

Product Features and Functional Benefits

- Less friction and product contact for easy cooking, cooling and freezing of products.
- Reduces back line pressure with up to 70%.
- Reduced dirt and oxide build up due to self cleaning surface.
- Finger plate for trouble free transfer.
- Bi-directional belt for long conveyors.

Available Moulded Module Sizes

- 200 mm / 7.87 inch module
- 100 mm / 3.94 inch module
- 50 mm / 1.97 inch module
- 33 mm / 1.30 inch module

Technical Information

BELT MATERIAL	BELT STRENGTH				TEMPERATURE		BELT WEIGHT Kg/m ² / lb/ft ²
	Straight		Curve		°C / ° F (min.)	°C / ° F (max.)	
	N/mm	lb/ft	N/mm	lb/ft			
PP (Polypropylene)	17600	1206	-	-	+5 / +41	+90 / +194	6,8 / 1,4
PE (Polyethylene)	17600	1206	-	-	+5 / +41	+118 / +245	6,8 / 1,4
POM (Polyacetal)	29700	2035	-	-	-43 / -45	+110 / +230	10,4 / 2,13

Standard Belt Widths

WIDTH (W)				BELT WIDTH TOLERANCE (max.)
PP-PE		POM		
mm	inch	mm	inch	
200,0	7.87	200,0	7.87	± 1 mm
250,0	9.84	250,0	9.84	± 1 mm
300,0	11.81	300,0	11.81	± 2 mm
350,0	13.77	350,0	13.77	± 2 mm
400,0	15.75	400,0	15.75	± 2 mm
450,0	17.71	450,0	17.71	± 2 mm
500,0	19.69	500,0	19.69	± 2 mm
550,0	21.65	550,0	21.65	± 3 mm
600,0	23.62	600,0	23.62	± 3 mm
650,0	25.60	650,0	25.60	± 3 mm
700,0	27.56	700,0	27.56	± 3 mm
750,0	29.50	750,0	29.50	± 3 mm
800,0	31.50	800,0	31.50	± 3 mm
850,0	33.46	850,0	33,46	± 4 mm
900,0	35.43	900,0	35,43	± 4 mm

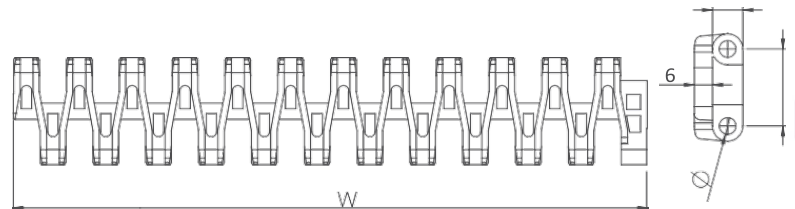

MD254 RR Comb / Finger Plate is available

This product is used for transferring of cans, bottles, etc.

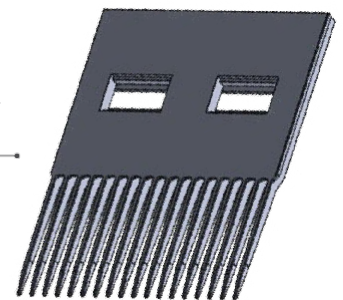

- Standard belt increments 50mm
 - Non-standard belt increments 16.6 mm
- Please contact with customer service for precise belt measurements

Sprockets and Technical Specifications

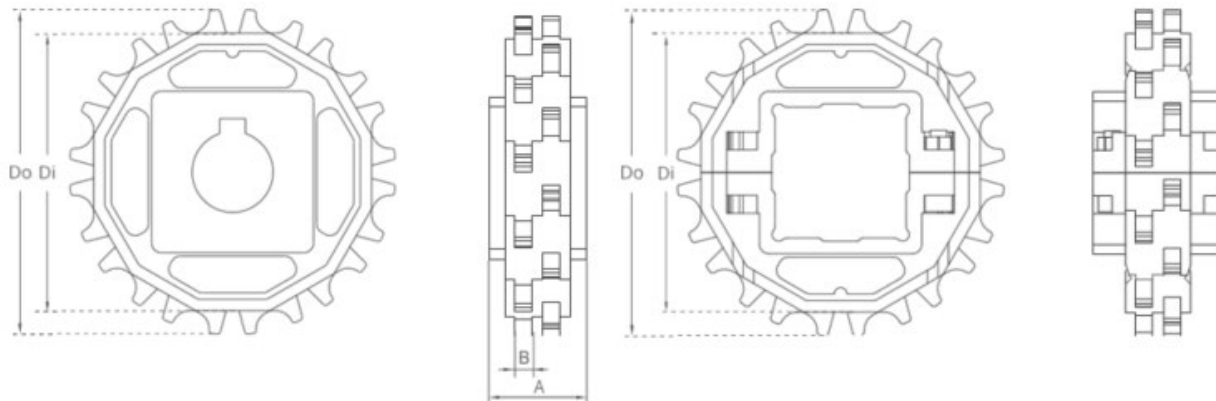

Standard Sprocket Dimensions

NUMBER OF TEETH	Di mm / inch	Do mm / inch	B mm / inch	A mm / inch	Square Bore (Q) mm / inch	Round Bore (R) mm / inch	PRODUCT CODE	
							Square Type (Q)	Round Type (R)
Z8	52,0 / 2.05	67,0 / 2.64	6 / 0.24	30 / 1.18	25 / 1	25 / 1	FL-MD-TR-254SQ25Z8	FL-MD-TR-254SRZ8
Z10	69,0 / 2.72	84,0 / 3.31	6 / 0.24	30 / 1.18	40 / 1.5	25-30 / 1-1.25	FL-MD-TR-254SQZ10	FL-MD-TR-254SRZ10
Z12	85,8 / 3.38	100,8 / 3.97	6 / 0.24	30 / 1.18	40 / 1.5	25-30 / 1-1.25	FL-MD-TR-254SQZ12	FL-MD-TR-254SRZ12
Z15	110,8 / 4.36	125,8 / 4.95	6 / 0.24	30 / 1.18	40 / 1.5	25-30 / 1-1.25	FL-MD-TR-254SQZ15	FL-MD-TR-254SRZ15
Z16	119,1 / 4.69	134,1 / 5.28	6 / 0.24	30 / 1.18	40 / 1.5	25-30 / 1-1.25	FL-MD-TR-254SQZ16	FL-MD-TR-254SRZ16
Z18	135,6 / 5.34	150,6 / 5.93	6 / 0.24	30 / 1.18	40 / 1.5	25-30 / 1-1.25	FL-MD-TR-254SQZ18	FL-MD-TR-254SRZ18
Z20	150,7 / 5.93	167,3 / 6.59	6 / 0.24	30 / 1.18	40 / 1.5	25-30 / 1-1.25	FL-MD-TR-254SQZ20	FL-MD-TR-254SRZ20

- * Other sprockets and hub sizes are manufactured upon request
- * PA (Polyamide) and PP (Polypropylene) sprockets are available upon request
- * Machined split sprockets are available for each size

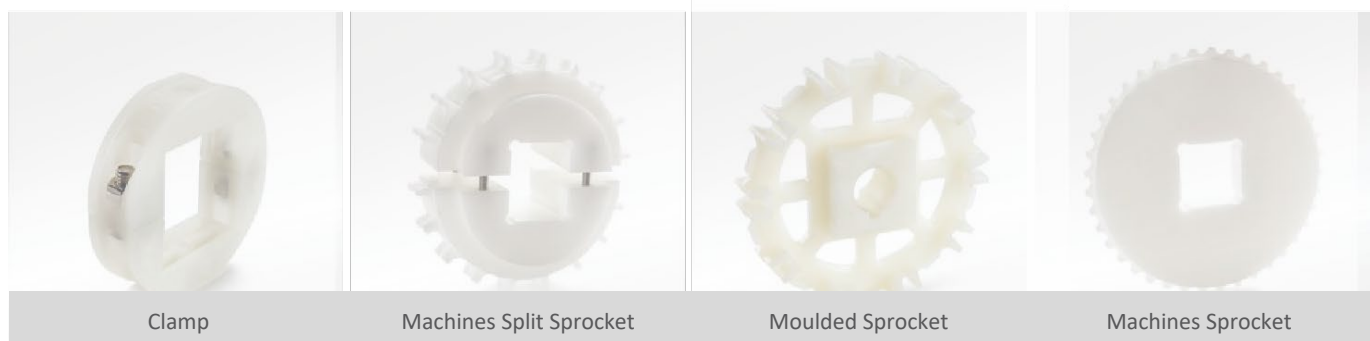



CLEAT AND SIDEWALLS

Product code	Cleat Height (mm / inch)	Cleat Width (mm / inch)	Product code	Sidewall Height (mm / inch)
FL-MD-254T25	25 / 1	200 / 7.87	FL-MD-254SW25	25 / 1
FL-MD-254T50	50 / 2	200 / 7.87	FL-MD-254SW50	50 / 2
FL-MD-254T75	75 / 3	200 / 7.87	FL-MD-254SW75	75 / 3
FL-MD-254T100	100 / 4	200 / 7.87	FL-MD-254SW100	100 / 4
FL-MD-254TC50	50 / 2	200 / 7.87	-	-
FL-MD-254TCH50	50 / 2	200 / 7.87	-	-
FL-MD-254TNC75	75 / 3	200 / 7.87	-	-
FL-MD-254TNC100	100 / 4	200 / 7.87	-	-

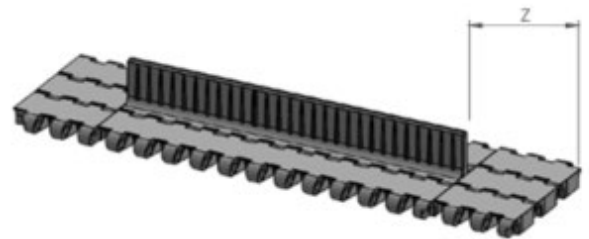
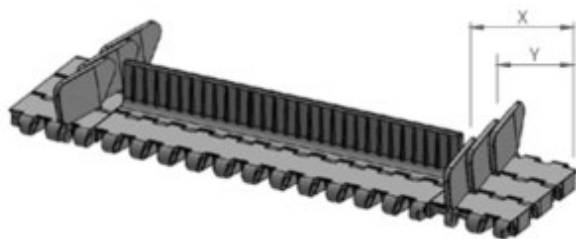
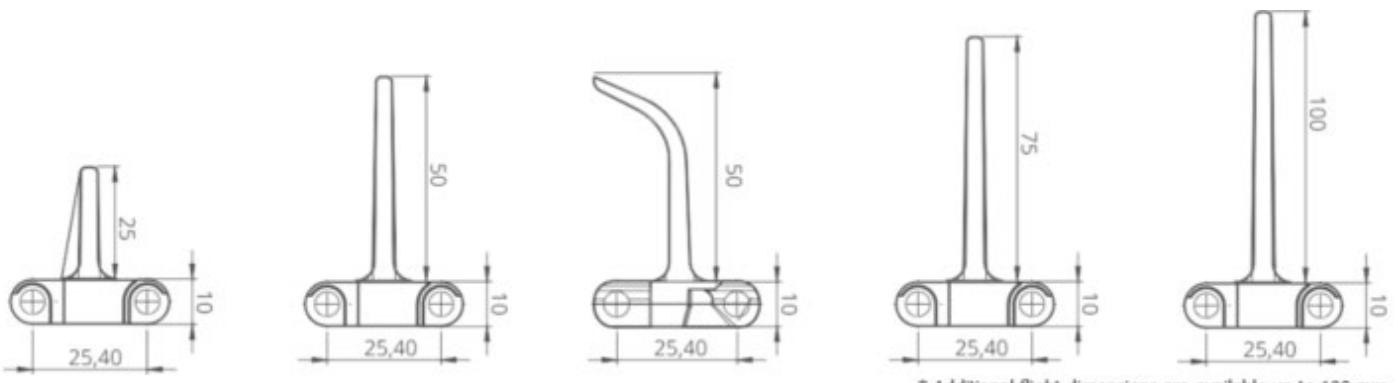

POSSIBLE SIDEWALL FREE ZONE	X		Y		POSSIBLE CLEAT FREE ZONE	Z	
	mm	inch	mm	inch		mm	inch
Standard, no module cutting	33,5	1.32	14,9	0.59	Standard, no module cutting	33,5	1.32
Non-Standard	41,9	1.65	23,3	0.92	Standard, no module cutting	50,0	1.97
Standard, no module cutting	50,0	1.97	31,6	1.24	Standard, module cutting	83,5	3.29
Non-Standard	58,6	2.31	39,9	1.57	Standard, no module cutting	100,0	3.94
Standard, module cutting necessary	66,9	2.63	48,5	1.91			
Non-Standard	75,2	2.96	56,8	2.24			

Note: Gap between cleat and sidewall minimum 2-3 mm

Non-standard cleat is upon request

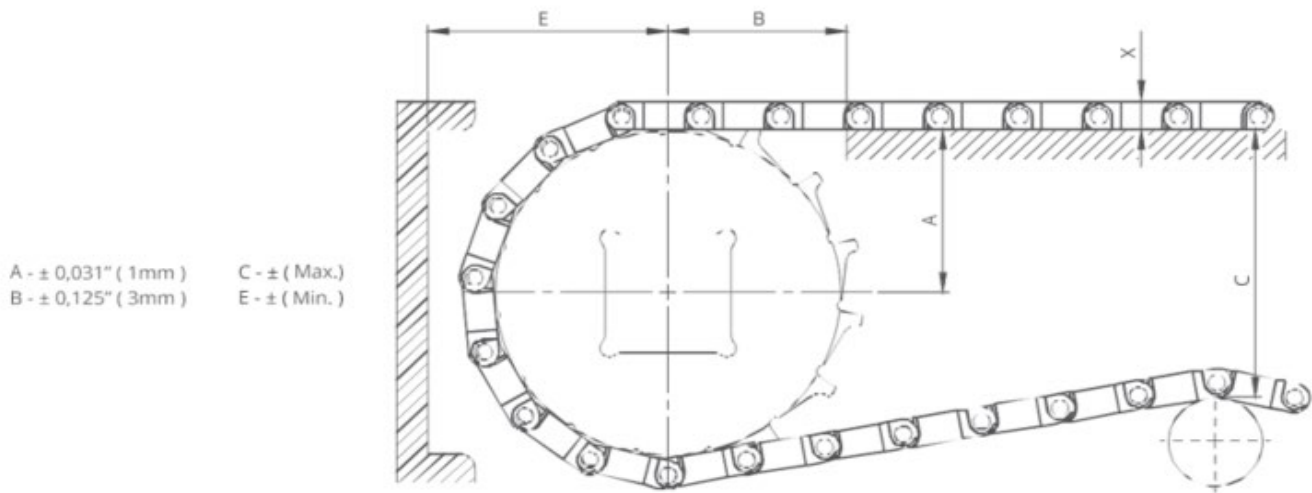

Conveyor Frame Dimensions

SPROCKETS DESCRIPTION		A		B		C		E		X		
Pitch Diameter		Range (Bottom to Top)		inch	mm	inch	mm	inch	mm	inch	mm	
inch	mm	inch	mm									
FabLink®MD25.4.FG, FabLink®MD25.4.C												
2.38	60,5	8	1.15	29,2	1.55	39,4	1.95	49,5	1.94	49,2	0.39	10,0
3.07	78,0	10	1.46	37,1	1.77	45,0	2.60	66,1	2.25	57,1	0.39	10,0
3.74	95,0	12	1.76	44,8	1.97	50,1	3.24	82,3	2.55	64,8	0.39	10,0
4.70	119,5	15	2.22	56,4	2.23	56,7	4.18	106,1	3.01	76,4	0.39	10,0
5.02	127,5	16	2.37	60,2	2.38	60,5	4.46	113,2	3.21	81,5	0.39	10,0
5.71	145,0	18	2.73	69,3	2.45	62,3	5.19	131,8	3.51	89,3	0.39	10,0
FabLink®MD25.4.RR, FabLink®MD25.4.GT												
2.38	60,5	8	1.15	29,2	1.55	39,4	1.95	49,5	2.18	55,4	0.64	16,3
3.07	78,0	10	1.46	37,1	1.77	45,0	2.60	66,1	2.48	63,1	0.64	16,3
3.74	95,0	12	1.76	44,8	1.97	50,1	3.24	82,3	2.79	70,9	0.64	16,3
4.70	119,5	15	2.22	56,4	2.23	56,7	4.18	106,1	3.25	82,7	0.64	16,3
5.02	127,5	16	2.37	60,2	2.38	60,5	4.46	113,2	3.46	87,8	0.64	16,3
5.71	145,0	18	2.73	69,3	2.45	62,3	5.19	131,8	3.76	95,5	0.64	16,3

Slider Support System for Straight Running Belts

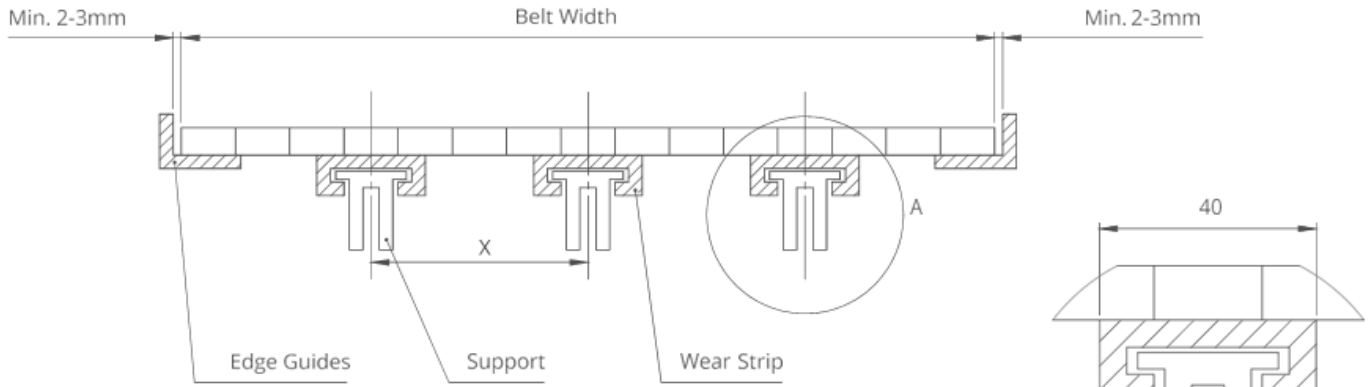

Note: The max. distances between the wear strips have to be (X) ;

125 mm for 2" belts
80 mm for 1" / 0.5" belts

Detail A
Scale 1:1

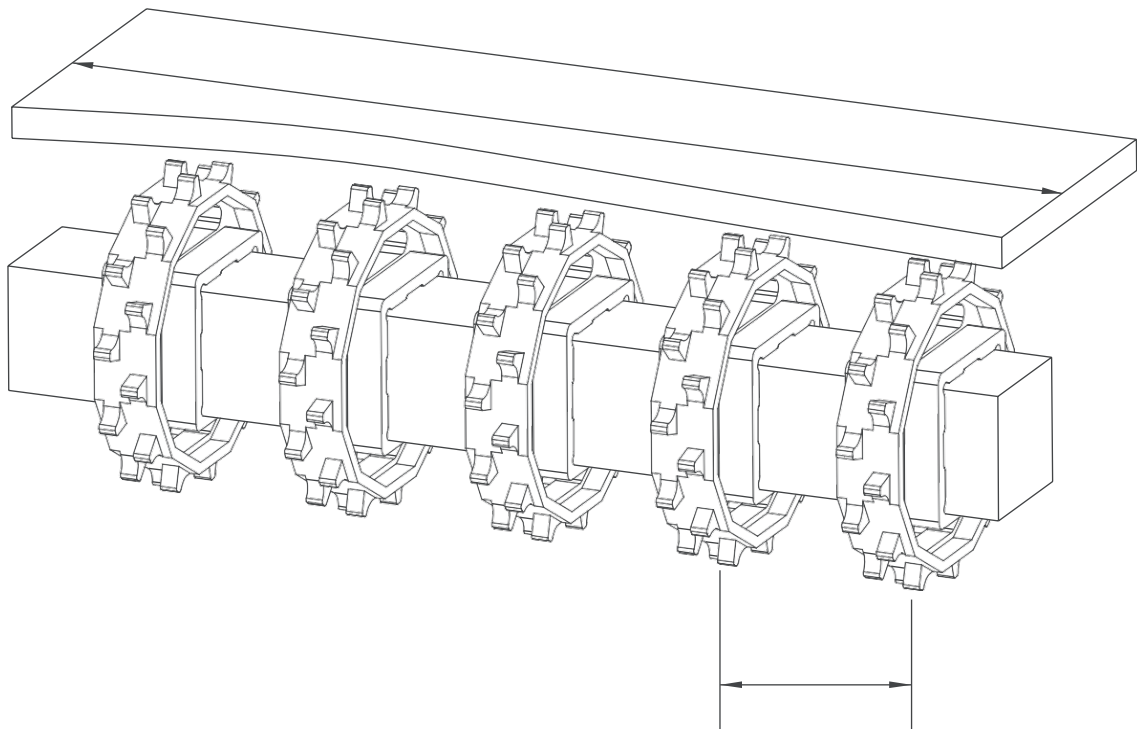

Sprockets Arrangement

Standard Belt Width		Number of sprockets per shaft		A (mm/inch)	
mm	inch	Drive Shaft	Return Shaft	Min.	Max.
150,0	6.0	2	2	50 / 2	120 / 4.7
200,0	8.0	2	2	50 / 2	120 / 4.7
250,0	10.0	3	2	50 / 2	120 / 4.7
300,0	12.0	3	2	50 / 2	120 / 4.7
350,0	14.0	3	3	50 / 2	120 / 4.7
400,0	16.0	4	3	50 / 2	120 / 4.7
450,0	18.0	4	3	50 / 2	120 / 4.7
500,0	20.0	5	4	50 / 2	120 / 4.7
550,0	22.0	5	4	50 / 2	120 / 4.7
600,0	24.0	6	5	50 / 2	120 / 4.7
700,0	26.0	7	5	50 / 2	120 / 4.7
800,0	28.0	8	6	50 / 2	120 / 4.7
900,0	30.0	9	7	50 / 2	120 / 4.7
1000,0	32.0	10	7	50 / 2	120 / 4.7

Note: number of sprockets depends on belt load