



## **FabLink<sup>®</sup>-EC25.4.R**

### **Meat Applications**

Spiral Freezer

### **Poultry Applications**

Spiral Freezer

### **Seafood Applications**

Freezing Lines, Spiral

### **Bakery Applications**

Spiral, Proofing, Cooling, Freezing Lines, Pan Handling

### **Fruits and Vegetables Applications**

Container Conveyance

### **Automotive Applications**

Car Part Manufacturing, Battery Filling

### **Packaging Applications**

Tray Packers, Box Transport Horizontal



# FabLink® EC25.4.R

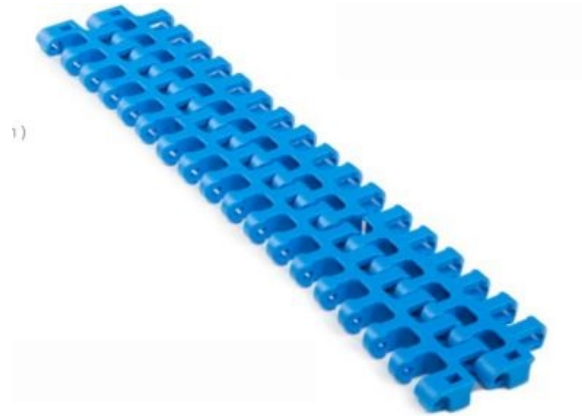

Pitch	25.8 mm / 1 inch
Belt surface	Open, Smooth Surface
Minimum width	100 mm / 3.94 inch
Open Area (%)	36% (Biggest opening 7.5 x 12mm)
Cleat	Yes ( T25, T50)
Sidewall	Yes ( h=25 mm)
Pin	∅ 5 mm / 0,197 inch – Self lock
Approved	FDA and EU
Curve	Yes
Color	Additional colors available
Cleanability	Excellent
Application:	Straight and side flexing
Collapse Factor:	2.1 – 2.4 (Please check page 169 to see Collapse Factors-Width Table)
Belt Thickness:	11 mm / 0.433 inch

## Product Features and Functional Benefits

Available for light and medium load capacity.  
 180 degree high speed side flexing applications.  
 High temperature and wear resistance.  
 Unique locking system.  
 Belt provides optimal open area for drainage and airflow.

## Available Moulded Module Sizes

200 mm / 7.87 inch module  
 100 mm / 3.94 inch module

## Technical Information

BELT MATERIAL	BELT STRENGTH				TEMPERATURE		BELT WEIGHT Kg/m <sup>2</sup> / lb/ft <sup>2</sup>
	Straight		Curve		°C / ° F (min.)	°C / ° F (max.)	
	N/mm	lb/ft	N/mm	lb/ft			
PP (Polypropylene)	20900	1430	1100	248	+5 / +42	+90 / +194	4,7 - 0.96
PE (Polyethylene)	-	-	-	-	-	-	-
Acetal	29700	2035	1650	372	-43 / -45	+110 / +230	7,0 - 1.44

Belt strength and temperature values are maximum on the table

## Standard Belt Widths

WIDTH (W)				BELT WIDTH TOLERANCE (max.)
PP-PE		POM		
mm	inch	mm	inch	
100,0	4.0	100,0	4.0	± 0,5 mm
150,0	6.0	150,0	6.0	± 0,5 mm
200,0	8.0	200,0	8.0	± 2 mm
250,0	10.0	250,0	10.0	± 2 mm
300,0	12.0	300,0	12.0	± 3 mm
350,0	14.0	350,0	14.0	± 3 mm
400,0	16.0	400,0	16.0	± 3 mm
450,0	18.0	450,0	18.0	± 3 mm
500,0	20.0	500,0	20.0	± 4 mm
550,0	22.0	550,0	22.0	± 4 mm
600,0	24.0	600,0	24.0	± 4 mm
650,0	26.0	650,0	26.0	± 4 mm
700,0	28.0	700,0	28.0	± 4 mm
750,0	30.0	750,0	30.0	± 4 mm
800,0	32.0	800,0	32.0	± 4 mm

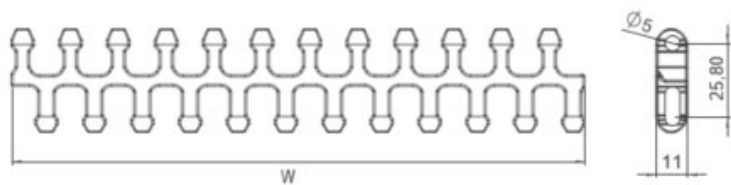

- Standard belt increments 50 mm
  - Non-standard belt increments 16.6mm
- Please contact with customer service for precise belt measurements and bigger sizes.

## Sprockets and Technical Specifications

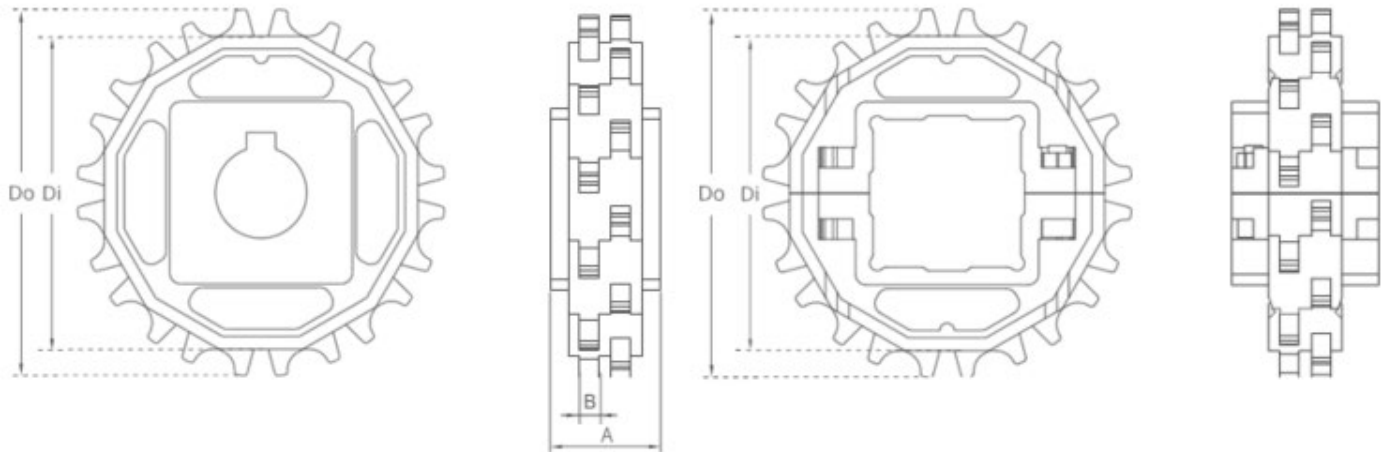

### Standard Sprocket Dimensions

NUMBER OF TEETH	Di mm / inch	Do mm / inch	B mm / inch	A mm / inch	Square Bore (Q) mm / inch	Round Bore (R) mm / inch	PRODUCT CODE	
							Square Type (Q)	Round Type (R)
Z8	52,0 / 2.05	67,0 / 2.64	6 / 0.24	30 / 1.18	25 / 1	25 / 1	FL-MD-TR-254SQ25Z8	FL-MD-TR-254SRZ8
Z10	69,0 / 2.72	84,0 / 3.31	6 / 0.24	30 / 1.18	40 / 1.5	25-30 / 1-1.25	FL-MD-TR-254SQZ10	FL-MD-TR-254SRZ10
Z12	85,8 / 3.38	100,8 / 3.97	6 / 0.24	30 / 1.18	40 / 1.5	25-30 / 1-1.25	FL-MD-TR-254SQZ12	FL-MD-TR-254SRZ12
Z15	110,8 / 4.36	125,8 / 4.95	6 / 0.24	30 / 1.18	40 / 1.5	25-30 / 1-1.25	FL-MD-TR-254SQZ15	FL-MD-TR-254SRZ15
Z16	119,1 / 4.69	134,1 / 5.28	6 / 0.24	30 / 1.18	40 / 1.5	25-30 / 1-1.25	FL-MD-TR-254SQZ16	FL-MD-TR-254SRZ16
Z18	135,6 / 5.34	150,6 / 5.93	6 / 0.24	30 / 1.18	40 / 1.5	25-30 / 1-1.25	FL-MD-TR-254SQZ18	FL-MD-TR-254SRZ18
Z20	150,7 / 5.93	167,3 / 6.59	6 / 0.24	30 / 1.18	40 / 1.5	25-30 / 1-1.25	FL-MD-TR-254SQZ20	FL-MD-TR-254SRZ20

\* Other sprockets and hub sizes are manufactured upon request

\* PA (Polamide) and PP (Polypropylene) sprockets raw material are available upon request

\*Machined Split Sprockets are available for each size



Clamp

Machines Split Sprocket

Moulded Sprocket

Machines Sprocket

Accessories and Technical Specifications

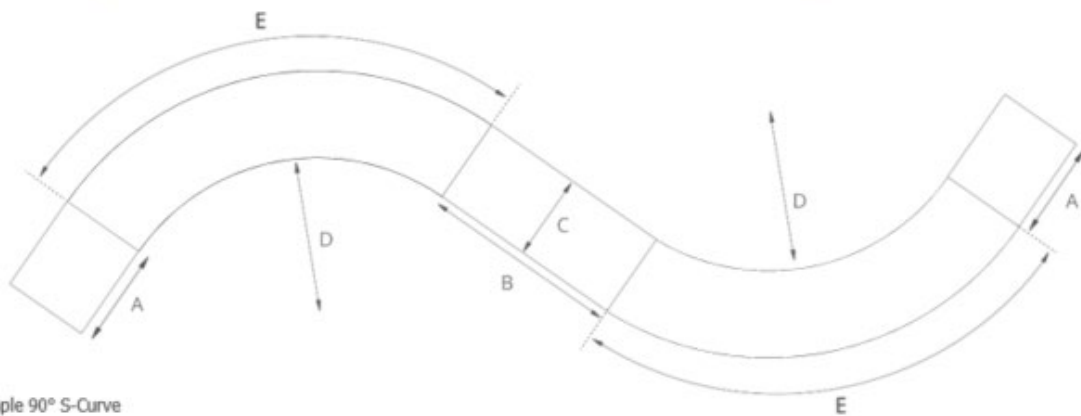
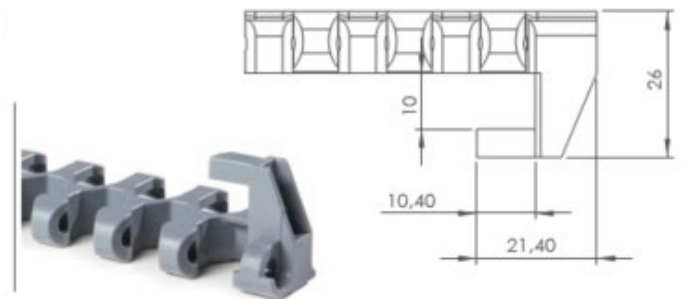
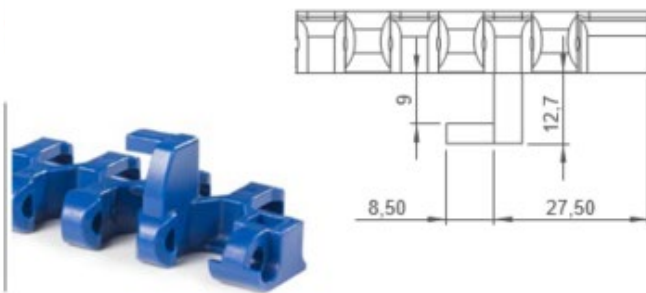
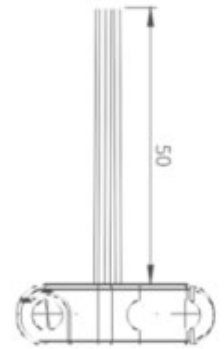
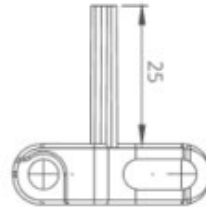

Radius Belt Example 90° S-Curve

Calculation Example

A: Straight run pull and n = Belt width  
 B: Straight run between 2 curves = min. 2 x belt width  
 C: Belt width  
 D: Minimum inner radius  
 E: Curve length

Min. inner radius  
 Collapse Factor =  $\frac{\text{Min. inner radius}}{\text{Belt width}}$   
 Minimum inner radius = Collapse Factor x Belt width

Belt width: 400 mm 90° Radius Belt  
 Collapse Factor: 2.14  
 D:  $400 \times 2.14 = 856 \text{ mm}$   
 A: 400 (Min)  
 B:  $2 \times 400 \text{ mm} = 800 \text{ mm (min.)}$   
 E:  $2 \times (C+D) \times 3.14 = 1972 \text{ mm}$

4

Total length =  $(2 \times A) + B + (2 \times E)$

## Engineering Information

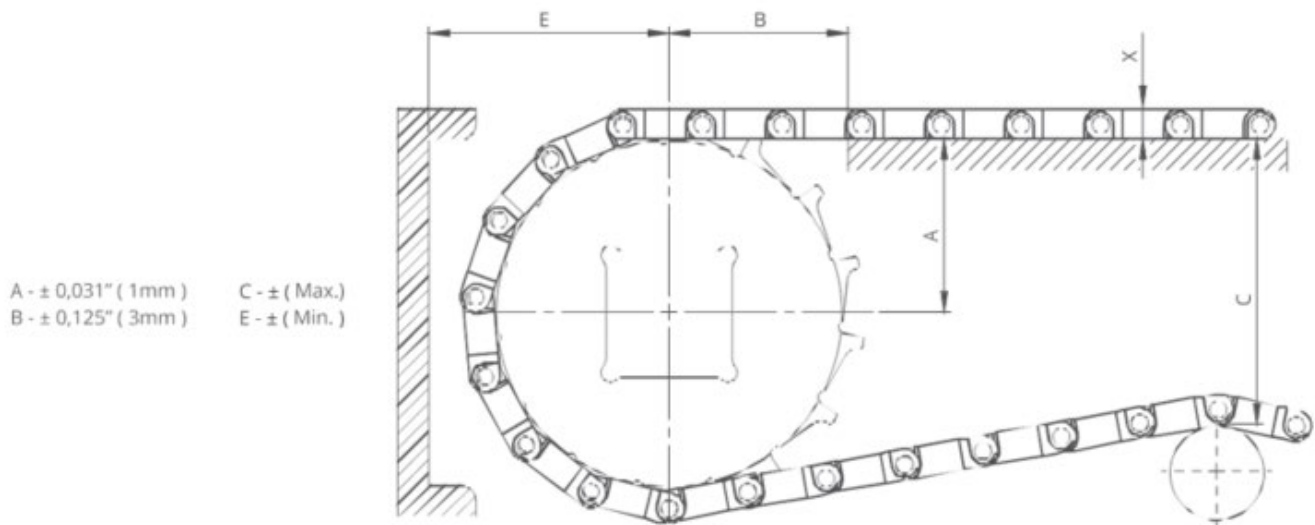

## Conveyor Frame Dimensions

SPROCKETS DESCRIPTION		A		B		C		E		X		
Pitch Diameter		Number of teeth	Range (Bottom to Top)		inch	mm	inch	mm	inch	mm	inch	mm
inch	mm		inch	mm								
FabLink®EC254 R												
2.38	60,5	8	1.15	29,2	1.55	39,4	1.95	49,5	1.94	49,2	0.43	11,0
3.07	78,0	10	1.46	37,1	1.77	45,0	2.60	66,1	2.25	57,1	0.43	11,0
3.74	95,0	12	1.76	44,8	1.97	50,1	3.24	82,3	2.55	64,8	0.43	11,0
4.70	119,5	15	2.22	56,4	2.23	56,7	4.18	106,1	3.01	76,4	0.43	11,0
5.02	127,5	16	2.37	60,2	2.38	60,5	4.46	113,2	3.21	81,5	0.43	11,0
5.71	145,0	18	2.73	69,3	2.45	62,3	5.19	131,8	3.51	89,3	0.43	11,0
FabLink®EC254 R-GT												
2.38	60,5	8	1.15	29,2	1.55	39,4	1.95	49,5	2.18	53,7	0.61	15,5
3.07	78,0	10	1.46	37,1	1.77	45,0	2.60	66,1	2.48	61,6	0.61	15,5
3.74	95,0	12	1.76	44,8	1.97	50,1	3.24	82,3	2.79	69,3	0.61	15,5
4.70	119,5	15	2.22	56,4	2.23	56,7	4.18	106,1	3.25	80,9	0.61	15,5
5.02	127,5	16	2.37	60,2	2.38	60,5	4.46	113,2	3.46	86,0	0.61	15,5
5.71	145,0	18	2.73	69,3	2.45	62,3	5.19	131,8	3.76	93,8	0.61	15,5



POSSIBLE SIDEWALL Indents	X	
	mm	inch
Standard, no module cutting	-	-
-	-	-
-	-	-

POSSIBLE Cleats Indents	Z	
	mm	inch
Standard, no module cutting	25,0	0.98
Standard, module cutting	37,5	1.48
Standard, module cutting	54,3	2.14

### Slider Support System for Straight Running Belts

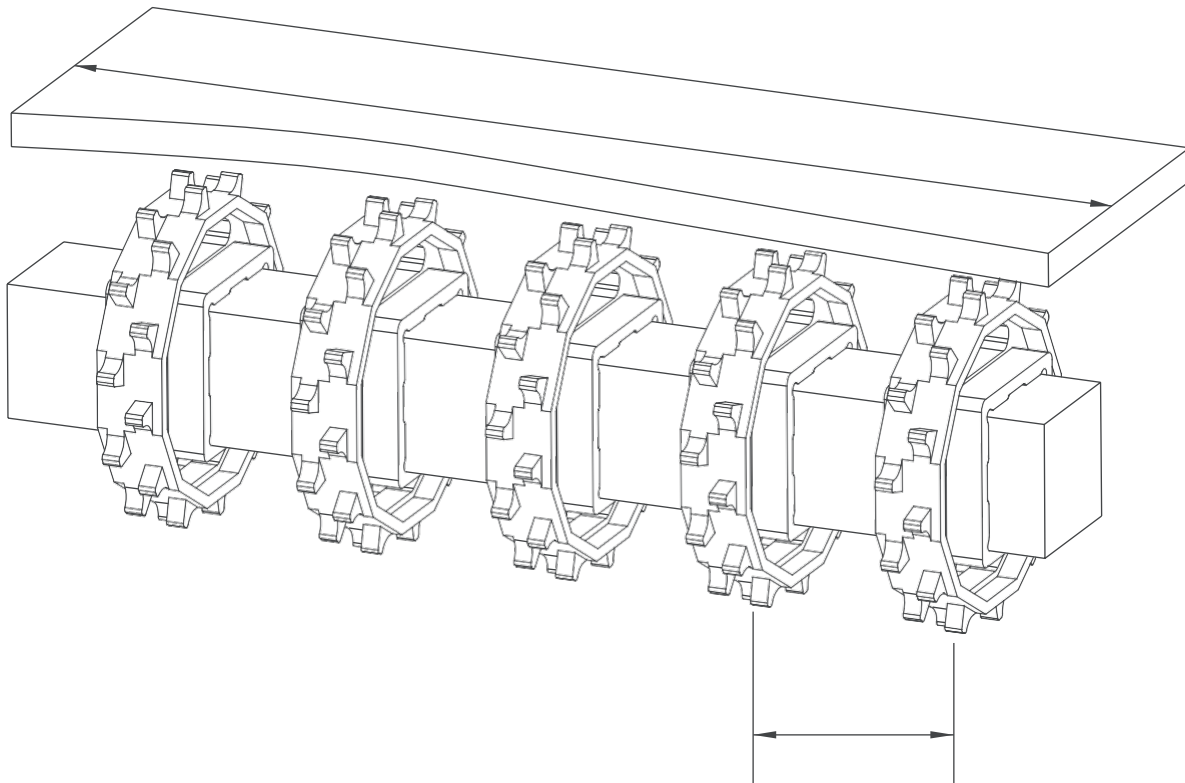

## Sprockets Arrangement

Standard Belt Width		Number of sprockets per shaft		A (mm/inch)	
mm	inch	Drive Shaft	Return Shaft	Min.	Max.
150,0	6.0	2	2	50 / 2	120 / 4.7
200,0	8.0	2	2	50 / 2	120 / 4.7
250,0	10.0	3	2	50 / 2	120 / 4.7
300,0	12.0	3	2	50 / 2	120 / 4.7
350,0	14.0	3	3	50 / 2	120 / 4.7
400,0	16.0	4	3	50 / 2	120 / 4.7
450,0	18.0	4	3	50 / 2	120 / 4.7
500,0	20.0	5	4	50 / 2	120 / 4.7
550,0	22.0	5	4	50 / 2	120 / 4.7
600,0	24.0	6	5	50 / 2	120 / 4.7
700,0	26.0	7	5	50 / 2	120 / 4.7
800,0	28.0	8	6	50 / 2	120 / 4.7
900,0	30.0	9	7	50 / 2	120 / 4.7
1000,0	32.0	10	7	50 / 2	120 / 4.7

Note: Number of sprockets depends on the belt load.

## Collapse factors per widths

Nom. Belt Width (mm)	250	300	350	400	450	500	550	600	650	700	750	800	850	900	950	1000	1050	1100	1150	1200
Nom Belt Width (inch)	10.0	12.0	14.0	16.0	18.0	20.0	22.0	24.0	26.0	28.0	30.0	32.0	34.0	36.0	38.0	40.0	42.0	44.0	46.0	48.0
Collapse Factor	2.07	2.10	2.12	2.14	2.15	2.16	2.17	2.18	2.18	2.19	2.19	2.19	2.20	2.20	2.20	2.21	2.21	2.21	2.21	2.21
Min Inner Radius (mm)	517.5	630.0	742.0	856.0	856.0	1080.0	1193.5	1308.0	1417.0	1533.0	1642.5	1752.0	1870.0	1980.0	2090.0	2210.0	2320.0	2431.0	2541.5	2652.0
Min Inner Radius (inch)	20.7	25.2	29.7	34.2	34.2	43.2	47.7	52.3	56.7	61.3	65.7	70.8	74.8	79.2	83.6	88.4	92.8	97.2	101.7	106.1

Standard range of belt width and collapse factor ( Min. Inner radius = Collapse factor x Standard belt width )