



BANDTRANSPORT EUROPE
CREATORS OF CONVEYOR BELTS

CURVE BELTS

FOR APPLICATION IN ROUND OR CURVE CONVEYORS



CURVE BELTS

Belts for round or curve conveyors

Specialised production

Polyurethane for sticky foodstuffs

Lightweight, acid-resistant belts for greenhouse horticulture

Special wear-resistant SD cover for building materials

For buffering and inclined transport in distribution centres

Also suitable for spiral conveyors

BTE specialises in assembly of complete conveyor belts. All possible technical tools and equipment are available to fabricate any conveyor belting style you may require. Fabricators and service providers in the conveyor belting industry benefit from considerable time savings provided by BTE's specialist services. Curve belts, the belts used in round or curve conveyors, form part of our product range.

Specialists in fabrication of curve belts

A round conveyor, aka curve conveyor or belt bend is applied in order to make better use of available space. It is an often-used belt in long production lines, for example in industrial bakeries, (greenhouse) agriculture, chocolate factories, distribution centres and production of building materials.

Fabrication of curve belts is a specialist, meticulous process. The tiniest measuring or cutting error inevitably leads to practical problems, as the belt will not run properly and will jerk or ripple. Throughout the years, BTE has developed the specialist skills and knowledge necessary to fabricate high quality curve belts. BTE has developed a variety of belt materials for the different applications, offering a choice of polyurethane (PU) and PVC belts.

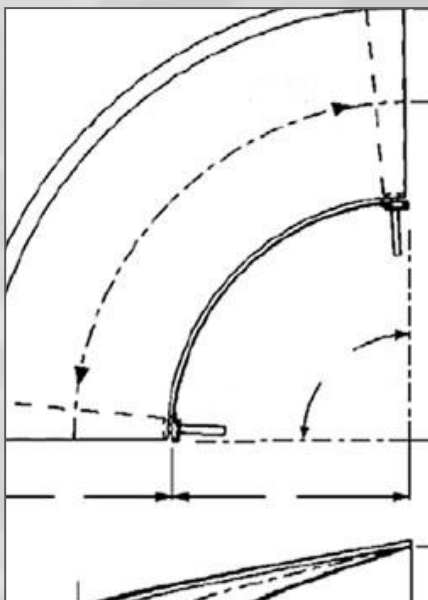

PU belts for sticky foodstuffs

BTE's polyurethane (PU) curve belts are mainly used to convey sticky (dough) products e.g. in industrial bakeries and for unpacked chocolate. They are also often applied during production of ready-made meals and snacks.

These belts are available with a diamond profile or a smooth top cover. Due to their construction and composition they are particularly suitable for use with knife-edge transfers. If required, belts can be supplied with punched hole patterns, eyelets or runners.



Lightweight, acid-resistant belts for greenhouse agriculture

BTE's wide range of PVC belts is often applied for harvesting and processing of cut flowers in greenhouses. Long conveyors are used to transport flowers through the greenhouse and the curve belts applied are often fitted with soft PVC spill edges to fixate the flowers on the belt without damaging them.

These particularly wear-resistant belts come with an acid-resistant, 0.7 mm thick cover and a special 'ultralight' fabric enabling tail drums with diameters as small as 30 mm.

Wear-resistant belts: BTE's special SD cover

Belts used for production and processing of bricks and other building (raw) materials need to have a wear-resistant cover for a long service life.

BTE has developed a special, wear-resistant cover, the SD cover, which is applied on our own coating line. With this cover, every belt more than meets the requirements for wear-resistance, resulting in a long service life, even under the challenging circumstances in this industry.

Distribution centres: buffering and inclines

Distribution centres have a set of requirements of their own when it comes to the curve belts applied. In this industry buffering of boxes and inclined conveying, e.g. in spiral conveyors, are important.

For these applications, too, we offer bespoke curve belts. More information about spiral conveyors can be found at the right hand bottom side of this page.



Our range of belt materials for curve belts

Bakery & pasta / Ready-made meals & Snacks / Cocoa & Chocolate

White	UG21-24 (smooth)
	UM21-24 (matt)
Blue	UG21-84 (smooth)
	UM21-84 (matt)

Plants and flowers and related industries

Green	21-14 1L
Grey	21-44 1L
Beige	21-64 1L

Transport and storage

Black	21-37 ii 1L
Grey	21-43/3

Building materials

Green / transparent	21-13SD
---------------------	---------

Spiral conveyors

Although nowadays the belts in spiral conveyors are often modular belts, in some applications regular belts are still preferable.

Fabrication of curve belts for spiral conveyors is a specialist process, at which BTE has skilled itself over the years.

Small faults will lead to big complications, which is why our customers are happy to leave the fabrication of these curve belts in our capable hands.



Bandtransport Europe BV

Bandtransport Europe BV (BTE) has originated from Fabreeka Bandtransport BV at the end of 2010, after a management buy out. BTE is continuing on Fabreeka's successful journey in development, production and marketing of process and conveyor belts for application in just about every possible industry.

Solutions

Worldwide we have a reputation to uphold, which we hope to further develop over time. We stand for quality, flexibility, speed and reliability. Bespoke consultancy and optimal service levels lead to solutions for the most diverse problems.

Development

At BTE, in conjunction with our suppliers, we continuously invest in research and development. This leads to constant further improvement of the quality and durability of our products and services.

Core values

We are aware that satisfied customers and healthy employees, as well as sustainable products, work environment and investments make a healthy company. This is why quality and sustainability, combined with safety, form the three core values of BTE. In order to realize this we utilize a management system in which our core values have been integrated. The system is based on the standards ISO 9001, ISO 14001 en de OSHAS 18001.

VISITING ADDRESS

Molenwerf 12
1911 DB Uitgeest
The Netherlands

POSTAL ADDRESS

P.O. Box 133
1910 AC Uitgeest
The Netherlands

CONTACT

T +31 (251) 319 119
F +31 (251) 319 118
info@bandtransporteurope.nl